

O₃ Ancillaries

triogen[®] O₃ ancillary equipment are designed to ensure an optimum operation and guarantee a premium water treatment using triogen[®] O₃ ozone generators. These are recommended for either 'slipstream' or 'full flow' ozone treatment installations.

INJECTORS

Inducing of ozone in water

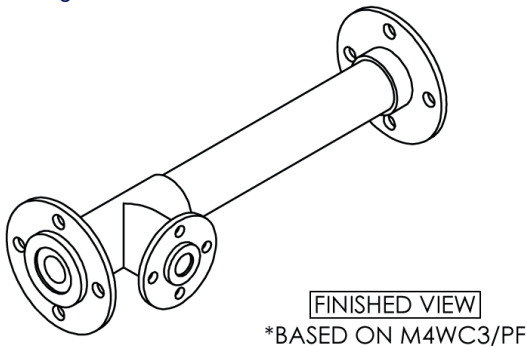

TECHNICAL DATA MODEL	Bin ref	Max airflow (m ³ /hr)	Water flow (m ³ /hr)
M5AC1/PU	INJ0021	0.7	1.6
M5AC2/PU	INJ0020	1.3	3.2
M4WC1/PU	INJ0006	2.7	6.0
M4WC2/PU	INJ0007	5.4	12.0
M4WC3/PF	INJ0008	8.1	18.0
M4WC4/PF	INJ0009	10.8	24.0
M4WC5/PF	INJ0010	13.5	30.0
M4WC6/PF	INJ0011	16.2	36.0
M4WC7/PF	INJ0012	18.9	42.0
M4WC8/PF	INJ0013	21.6	48.0
M4WC9/PF	INJ0026	24.3	54.0
M4WC10/PF	INJ0014	27.0	60.0
M4WC35/PF	INJ0027	35.0	76.0

- Material: uPVC
- Permanent joint assembled with tangit solvent cement
- Unions are metric type GF ref 31.64.01
- Nominal pressure rating 10 bar at ambient temperature
- Flanges BS EN 1092-1 NP16
- Water boost pressure required 2 bar
- Maximum line pressure 1.2 bar

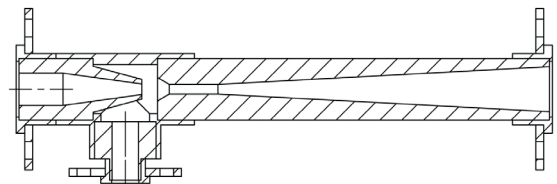

SECTION A-A

IN-LINE STATIC MIXERS

Mixing of ozone in water

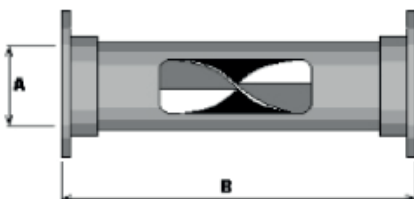

TECHNICAL DATA MODEL	A=pipe N.B		B=length	Flowrate m ³ /hr	Pressure Drop	Flowrate m ³ /hr	Pressure Drop
	mm	inches	mm	velocity 2m/sec	psi	velocity 3m/sec	psi
SM1/2/P	25	1"	177	3.6	1.5	5.3	3.5
SM1.5/2/P	40	1 1/2"	231	9	1.5	14.5	3.5
SM2/2/P	50	2"	275	15	1.5	21.5	3.5
SM3/2/P	90	3"	260	36	1.4	55	2.1
SM4/2/P	110	4"	325	57	1.4	85	2.1
SM6/2/P	160	6"	465	135	1.4	190	2.1
SM8/2/P	200	8"	628	225	0.85	340	2
SM10/2/P	250	10"	761	350	0.85	525	2
SM12/2/P	300	12"	900	500	0.85	760	2

O₃ Ancillaries

OFF GAS DESTRUCTORS

Destroying excess of ozone before venting to atmosphere

TECHNICAL DATA MODEL	Vented Air Flow	Weight of vessel	Weight of carbon	Weight of gravel	Connections
	m ³ /h	kg	kg	kg	inches
ACF10 (1)	10	14	25	7	1 1/4"
ACF30 (2)	20	48	50	25	2" & 1"
ACF60 (2)	30	80	40	125	3" & 1"

- 1) The destructor vessel is constructed from uPVC and supplied with water level indicator as shown.
- 2) The destructor vessel is constructed from GRP wrapped uPVC and supplied with painted metal stand as shown. Flange connections are BS4504 NP10 as standard ANSI 150 RF can be supplied on request.

ACF10

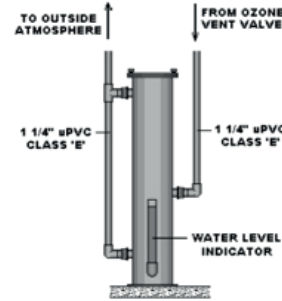

ACF30

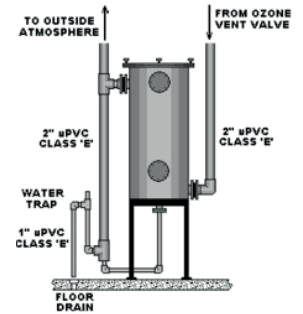

ACF60

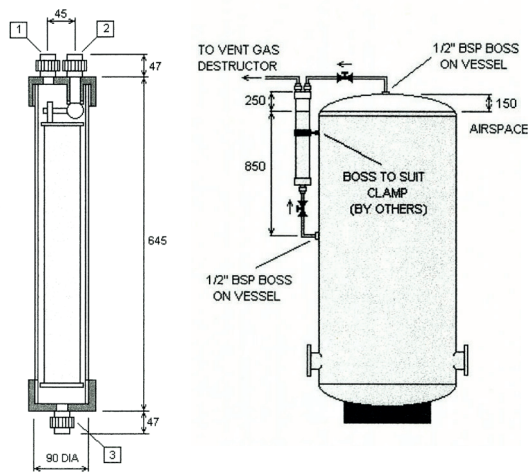
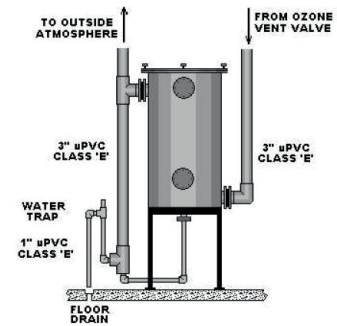

AUTOMATIC VENT VALVE ALCV3-13

Equipping your contact tank with the most reliable degassing valve.

TECHNICAL DATA MODEL	Union inches			LxØ
	1	2	3	mm
ALCV3.13	1/2"	1/2"	1/2"	689 x40

Materials of Construction

- Top and bottom caps - uPVC
- Valve body - clear uPVC
- Float assembly - uPVC
- Ball and stem - uPVC
- Ball seat - PTFE

CONTACT

Triogen Limited
Unit 14 Langlands Place, East Kilbride G75 0YF
Scotland, United Kingdom
Tel: + 44 (0) 13 55 220 598
Fax: + 44 (0) 13 55 570 058
www.triogen.com
info@triogen.com

© 2020 • Subject to change without notice. • www.triogen.com

triogen_BIO-UV_03_Ancillaries_EN_V1



Your local distributor: