

Introducing the Autobag® 850S™ Mail Order Fulfillment System – The most technologically-advanced system for mail order fulfillment bagging.

The new Autobag® 850S™ bagger is uniquely designed to provide enhanced packaging productivity for mail order fulfillment applications. Capable of running bags up to 550mm wide, this system features a breakthrough bag opening technology that securely grips and holds the open bag in place. This creates a large, square opening (up to 275 x 275mm) that allows for easy loading of single or multi-line orders.

Next-bag-out printing is achieved with an advanced thermal transfer imprinter positioned directly over the next bag to be loaded. This ensures accuracy and efficiency in fulfillment applications that require frequent product and label changeovers, and prevents product queuing.

State-of-the-art engineering has resulted in a system that is inherently safe. The Autobag 850S eliminates the need for bulky guarding or devices required for safe operation. This unobstructed access makes loading ergonomic and improves operator throughput.

When used with genuine Autobag pre-opened bags, the Autobag 850S is the next evolution of high-quality, reliable and flexible mail order fulfillment packaging, backed by the industry's most comprehensive engineering and field service network.

Markets Served

- Single or multi-line mail order fulfillment
- Prescription-by-mail fulfillment
- Apparel
- Fashion Accessories
- Sporting Goods
- Footwear



Next-bag-out printing prevents product queuing and reduces waste



Simple bag threading for easy changeover to keep production lines running smoothly



Programmable pass-through up to 275mm for maximum flexibility



Unobstructed access for easy loading of products

Features and Benefits

Extra Large Bag Sizes

Capable of running bags up to 550mm wide

High Quality Seals

Coordinated seal flattener for wrinkle free seals

Continuous Film Control

A sophisticated tension control unit centres and monitors the position of the film throughout the entire bagging process

Compact

Compact footprint minimises floor space

Flexible

Easily integrates with third-party systems

Adjustable

Simple height adjustment and casters for operator comfort and portability

Breakthrough Technology

Advanced bag opening system enables the use of a smaller, more completely filled bag



Easy Loading

Modular bag storage shelf that speeds bag changeovers



Intuitive Interface

AutoTouch™ Control Screen accesses operator tutorials, help system, on-board diagnostics, data retrieval, and performance monitoring. It features menu or graphic-based selection options



System Matched Bags



Service & Support



Custom Engineering & Integration

Optional Additions

- Rear Takeaway Conveyor (Optional label up mechanism)
- Side Exit Takeaway Conveyor

Technical Information

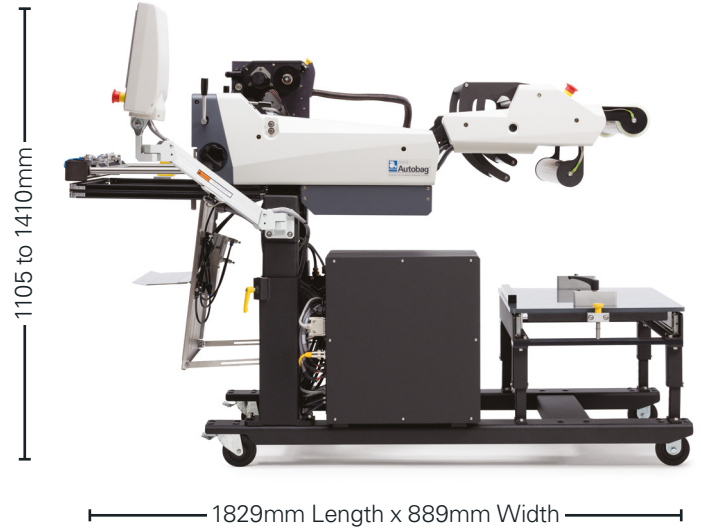

Weight	318kg
Electrical	110/220 VAC switchable 50/60 Hz, 1,800 watts continuous
Air Feed	5 CFM/80 psi of clean, dry air
Pass-Through	Up to 275mm
Bag Thickness	35 to 100 µm
Bag Sizes	W 254 to 550mm L 254 to 900mm
Weight Capacity	Up to 4.5kg (with load shelf)