



Official Website:

Our experienced team of professional engineers can provide you with products and technical solutions for your needs

For more product information, please visit our official website:

www.innofluid.com



OFFICIAL WEBSITE

INNOFLUID CO.,LTD.

SHENCHEN PERISTALTIC PUMP

Exported to **106** countries



Easypump obtained U.S. Invention patent and Appearance patent.



Invention Patent No.: US 11,852,136 B2
Appearance patent No.: US D939,692 S

Easypump obtained EU Appearance patent.



Appearance patent No.: 008005789-0002

APPLICATION

Biological Technology

In biological laboratories, the peristaltic pumps play a key role in cell culture. Peristaltic pump can provide culture medium and automatic liquid addition to realize many functions like liquid circulation and mixing.

For providing culture medium, Shenchen LabN series peristaltic pump can transport culture medium stored in containers to cell culture vessels according to different flow requirements.

For automatic liquid addition process, Shenchen LabF series peristaltic pump can add equal amounts of liquid to multiple culture media according to preset parameters, ensuring a stable supply of culture media, reducing manual operations, and also achieving standardization and accurate control of the culture process.



Medical Equipment Supporting

In liposuction surgery, peristaltic pumps are mainly used for local swelling and anesthesia. A peristaltic pump injects a solution containing saline, lidocaine, epinephrine, and sodium bicarbonate under the liposuction site. In this process, except for the liquid-carrying device, the fluid path does not contact any parts, and the liquid reaches the affected area directly, which is hygienic and has no cross-contamination. For this application, it can be matched with Shenchen EasyPump pump head or LabV series products which have the quantitative measuring function, it can accurately control the liquid flow, automatically stop after completing the amount of liquid. This product also can be matched with foot pedal switch. Shenchen peristaltic pump runs smoothly and is easy to operate. It only needs to replace the hose regularly for follow-up maintenance. It is an ideal choice for medical equipment.

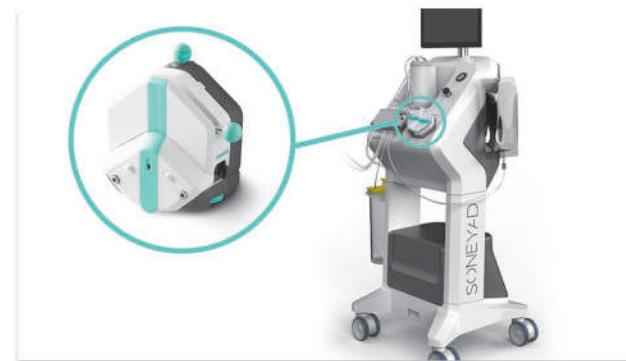

Environmental Resources

Sewage water quality is very important for the adjustment of various process parameters in the sewage treatment process. Therefore, the detection and statistics of sewage water quality are the key points of control in the sewage treatment process. During the experiment, sewage needs to be sampled in batches. Sometimes it is necessary to regularly and quantitatively collect high-specific gravity liquids or solid-containing particle suspensions. Sometimes it is necessary to sample in layers. Sometimes it is necessary to collect and transport water samples over long distances without cross-contamination. Shenchen peristaltic pump LabV series has three metering modes: Fixed volume, dispensing, and timed start/stop, which can meet various transmission and distribution requirements.



CONTENTS

01 Laboratory Peristaltic Pump

Lab Series Function comparison	01
Lab Series Specification comparison	02
LabV Series	03
LabF Series	05
LabN Series	07
LabM Series	09
LabV3-IV	11

02 Compact Laboratory Peristaltic Pump

LabK	13
LabQ	14
LabT	15
ST-HandyPump	16

03 Suitable Pump Head

EasyPump	19
AMC	21
KD15/KD25	22
KT15	23
HandyPump	24
UC15/20	25
MiniPump	26
MicroPump	27

04 Peristaltic Pump Tubing

28

05 Peristaltic Pump Accessories

31



LabV6-III

LabF6-III

LabN6

LabM6

LabV3-IV



Lab series

LABORATORY PERISTALTIC PUMP

Function comparison

Function	Model	LabV	LabF	LabN	LabM
Color LCD Screen		•	•	•	
LED Display/Indicator Light					•
Flow Rate		•	•	•	
Speed Rate		•	•	•	•
Touch Screen Control		•	•		
Keypad Control		•	•	•	•
Knob Control				•	
Open Head Stop Running (Optional)		•	•	•	
Flow Rate Calibration		•	•	•	
Liquid Transmission Function		•	•	•	•
Liquid Volume/ Time Dispensing		•	•		
Speed/Time Dispensing			•	•	•
Fixed volume		•			
Dispensing		•	•		
Back Suction Angle		•	•	•	
Set Date & Time		•	•		
Power Down Memory		•	•	•	•
Active switch signal, 5V/24V universal(Start/stop, direction)		•	•	•	•
Active switch signal, 5V/24V universal(Flushing function)		•	•	•	
Passive switch signal(foot pedal/handheld dispenser/ start/stop)		•	•	•	•
Passive switch signal (direction)					•
Speed adjusting by analog input (0-10V/0-5V/4-20mA)		•		•	•
RS232 interface		•	•	•	•
RS485 interface (Modbus protocol RTU mode)		•	•	•	•
Output operating status (Open collector output)		•	•	•	

Specification comparison

Technical Parameter	Model	LabV Series	LabF Series	LabN Series	LabM Series
Display		Industrial grade 4.3" LCD color display	Industrial grade 4.3" LCD color display	3.2" high definition LCD screen	3 digital LED
Control method		Touch screen and Mechanical keypad	Touch screen and Mechanical keypad	Digital knob and Mechanical keypad	Mechanical keypad
Keypad lifetime		300,000 times	300,000 times	300,000 times	300,000 times
Speed range		0.1-600 rpm	0.1-600 rpm	0.1-600 rpm	0.1-600 rpm
Speed Control		Touch screen/Analog signal/Communication	Touch screen/Communication	Digital knob/Analog signal/Communication	Keypad/Analog signal/Communication
Speed resolution		0.01rpm	0.01rpm	0.01rpm	0.1rpm when the speed is 0-100rpm, 1rpm when the speed is 100-600rpm.
Flow rate resolution		0.01 mL/min	0.01 mL/min	/	/
Dispensing volume range		0.01-9999L 0.01-9999mL	0.01-9999mL	/	/
Dispensing time		0.1-9999s	0.1-9999s	0.1s-9999h	0.5-999s
Pause time		0.1-9999s	0.1-9999.99s	/	/
Copy numbers		1-9999 times, setting'0'means unlimited	1-9999 times, setting'0'means unlimited	1	1
Back suction angle		0-360°	0-360°	0-360°	/
Motor type		LabV series: Stepper motor LabV-III series: Closed-loop stepper motor	LabF series: Stepper motor LabF-III series: Closed-loop stepper motor	LabN series: Stepper motor LabN-III series: Closed-loop stepper motor	LabM series: Stepper motor LabM-III series: Closed-loop stepper motor
Start/stop, direction signal		Passive switch signal, such as foot pedal switch; Active switch signal:5-24V universal	Passive switch signal, such as foot pedal switch; Active switch signal:5-24V universal	Passive switch signal, such as foot pedal switch; Active switch signal:5-24V universal	Passive switch signal, such as foot pedal switch; Active switch signal:5-24V universal
External speed control signal		0-5V, 0-10V, 4-20mA for option	/	0-5V, 0-10V, 4-20mA for option	0-5V, 0-10V, 4-20mA for option
Communication interface		RS232, RS485 support Modbus protocol(RTU mode)	RS232, RS485 support Modbus protocol(RTU mode)	RS232, RS485 support Modbus protocol(RTU mode)	RS232, support Shenchen protocol RS485, support Modbus protocol (RTU mode)
Output interface		Output motor working status (Open-Collector output)	Output motor working status (Open-Collector output)	Output motor working status (Open-Collector output)	/
Power supply		AC 220V±10% 50Hz/60Hz (standard) AC 110V±10% 50Hz/60Hz (optional)	AC 220V±10% 50Hz/60Hz (standard) AC 110V±10% 50Hz/60Hz (optional)	AC 220V±10% 50Hz/60Hz (standard) AC 110V±10% 50Hz/60Hz (optional)	AC 220V±10% 50Hz/60Hz (standard) AC 110V±10% 50Hz/60Hz (optional)
Drive dimension (L×W×H)		261.4×157.3×236.9mm	261.4×157.3×236.9mm	261.4×157.3×236.9mm	261.4×157.3×236.9mm
Power consumption		LabV series: <50w LabV-III series:<80w	LabF series: <50w LabF-III series:<80w	LabN series: <50w LabN-III series:<80w	LabMseries: <50w LabM-III series:<80w
Condition temperature		0-40°C	0-40°C	0-40°C	0-40°C
Relative humidity		<80%	<80%	<80%	<80%

Flow Rates Peristaltic Pump

- Industrial grade 4.3" true color LCD screen, touch screen control.
- Dynamic display transferring status. Flow rate data, setting parameters and system configuration display in the same screen.
- 3 Kinds of working mode: fixed volume metering, fixed time and volume, timer start and stop, meet different transferring and dispensing request.
- Intelligent calibration function and online micro adjusting function.



● Suitable Pump Head



● Screen Display

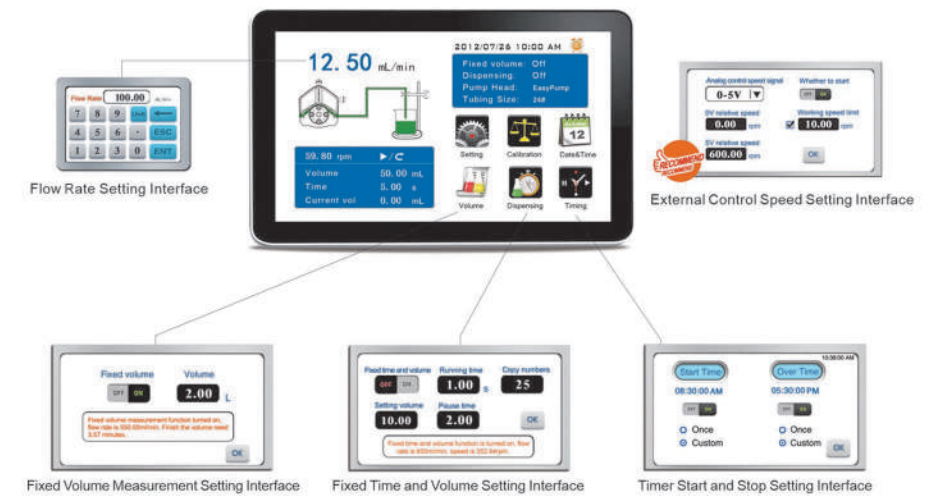

● Product Composition and Flow Rate Range

Flow Rates Peristaltic Pump		Pump Head & Flow Rate (mL/min)			
		EasyPump Series			
Tubing		EasyPumpI/III	EasyPumpII/IV	EasyPumpV/VI	
Drive&Speed		13", 14", 19", 16", 25", 17", 18"	15", 24", 35", 36"	13", 14", 19", 16", 25"	
LabV1-III	0.1-150 rpm	0.0053~645	0.18~775	0.0053~295	
LabV3-III	0.1-350 rpm	0.0053~1505	0.18~1808	0.0053~688	
LabV6-III	0.1-600 rpm	0.0053~2580	0.18~3100	0.0053~1180	
Tubing		AMC1~AMC12		KD15	KD25
		(10 rollers)	(6 rollers)	13", 14", 19", 16", 25", 17", 18"	15", 24"
Drive&Speed		Inner diameter: 0.13-3mm Wall thickness: 0.8-1mm			
LabV1	0.1-150 rpm			0.006~822.75	0.215~520.5
LabV3	0.1-350 rpm	0.0002-48(working speed ≤150rpm)	0.0002-65(working speed ≤150rpm)	0.006~1919.75	0.215~1214.5
LabV6	0.1-600 rpm			0.006~3240	0.215~2082

LabV series

Dispensing Peristaltic Pump

- Imported 4.3" industrial grade color LCD screen display, with touch screen control.
- Can preset dispensing volume, dispensing time, pause time and copy numbers.
- With intelligent calibration function and online micro adjusting function.
- The pump can store 60 commonly used filling modes.
- Back suction angle setting, avoid liquid drop off when the pump stops working.
- Two working mode: Volume dispensing and speed dispensing (special for viscous liquid)
- Can communicate with balance, closed-loop control.

● Embedded handle comfortable grip, convenient for users to take.



● ABS engineering plastic shell Anti-corrosion and anti-static protective coating

● Suitable Pump Head



● Screen Display



● Product Composition and Flow Rate Range Refer to page 20 for LabF6 series canned quantity reference

Dispensing Peristaltic Pump		Pump Head & Flow Rate (mL/min)			
		EasyPump Series			KD15
Tubing		EasyPumpI/III	EasyPumpII/IV	EasyPumpV/VI	
Drive&Speed		13", 14", 19", 16", 25", 17", 18"	15", 24", 35", 36"	13", 14", 19", 16", 25"	
LabF1-III	0.1-150 rpm	0.0053~645	0.18~775	0.0053~295	
LabF3-III	0.1-350 rpm	0.0053~1505	0.18~1808	0.0053~688	
LabF6-III	0.1-600 rpm	0.0053~2580	0.18~3100	0.0053~1180	
Tubing		AMC1~AMC12		KD15	KD25
		(10 rollers)	(6 rollers)		
Drive&Speed		Inner diameter: 0.13-3mm Wall thickness: 0.8-1mm		13", 14", 19", 16", 25", 17", 18"	15", 24"
LabF1	0.1-150 rpm			0.006~822.75	0.215~520.5
LabF3	0.1-350 rpm	0.0002-48(working speed≤150rpm)	0.0002-65(working speed≤150rpm)	0.006~1919.75	0.215~1214.5
LabF6	0.1-600 rpm			0.006~3240	0.215~2082

LabF series

Flow Rates Peristaltic Pump

- 3.2" color LCD screen display.
- Flow rate and motor speed display in same screen.
- Timing function, time range 0.1s-9999 hours, can be used for simple dispensing function.

● Embedded handle comfortable grip, convenient for users to take.



● ABS engineering plastic shell
Anti-corrosion and anti-static protective coating

Suitable Pump Head



EasyPump Series (adjustable pressure)



EasyPump Series (non-adjustable pressure)

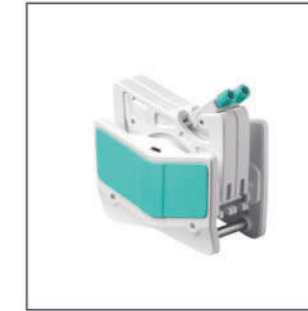

AMC Series



KD 15/25 (Coming soon)

Screen Display



Product Composition and Flow Rate Range

Flow Rates Peristaltic Pump		Pump Head & Flow Rate (mL/min)			
		EasyPump Series			
Tubing		EasyPumpI/III	EasyPumpII/IV	EasyPumpV/VI	
Drive&Speed		13", 14", 19", 16", 25", 17", 18"	15", 24", 35", 36"	13", 14", 19", 16", 25"	
LabN1-III	0.1-150 rpm	0.0053~645	0.18~775	0.0053~295	
LabN3-III	0.1-350 rpm	0.0053~1505	0.18~1808	0.0053~688	
LabF6-III	0.1-600 rpm	0.0053~2580	0.18~3100	0.0053~1180	
Tubing		AMC1~AMC12		KD15	KD25
		(10 rollers)	(6 rollers)	13", 14", 19", 16", 25", 17", 18"	15", 24"
Drive&Speed		Inner diameter: 0.13-3mm Wall thickness: 0.8-1mm			
LabN1	0.1-150 rpm			0.006~822.75	0.215~520.5
LabN3	0.1-350 rpm	0.0002-48(working speed≤150rpm)	0.0002-65(working speed≤150rpm)	0.006~1919.75	0.215~1214.5
LabN6	0.1-600 rpm			0.006~3240	0.215~2082

LabN series

Standard Peristaltic Pump

- 3 digital LED display motor speed, mechanical keypad control.
- Timing function, the time range of 0.5 seconds -999 seconds can be used as a simple dispensing.
- Support RS232 and RS485 communication, Modbus protocol.



Suitable Pump Head



Screen Display



Product Composition and Flow Rate Range

Standard Peristaltic Pump		Pump Head & Flow Rate (mL/min)			
		EasyPump Series			
Tubing		EasyPumpI/III	EasyPumpII/IV	EasyPumpV/VI	
Drive&Speed		13", 14", 19", 16", 25", 17", 18"	15", 24", 35", 36"	13", 14", 19", 16", 25"	
LabM1-III	0.1-150 rpm	0.0053~645	0.18~775	0.0053~295	
LabM3-III	0.1-350 rpm	0.0053~1505	0.18~1808	0.0053~688	
LabM6-III	0.1-600 rpm	0.0053~2580	0.18~3100	0.0053~1180	
Tubing		AMC1~AMC12		KD15	KD25
		(10 rollers)	(6 rollers)	13", 14", 19", 16", 25", 17", 18"	15", 24"
Drive&Speed		Inner diameter: 0.13-3mm Wall thickness: 0.8-1mm			
LabM1	0.1-150 rpm			0.006~822.75	0.215~520.5
LabM3	0.1-350 rpm	0.0002-48(working speed ≤150rpm)	0.0002-65(working speed ≤150rpm)	0.006~1919.75	0.215~1214.5
LabM6	0.1-600 rpm			0.006~3240	0.215~2082

LabM series

Flow Rates Peristaltic Pump

LabV3-IV



- Industrial Grade 4.3" true color LCD display, touch screen control.
- Dynamic display transferring status; Flow rate data, setting parameters, and system configuration display in the same screen.
- Three kinds of metering modes: fixed Volume metering, fixed time and volume, timer start-stop, meet different transferring and dispensing requirements.
- Intelligent calibration Function and online micro adjusting function.
- Function of stop working when uncover to ensure the operation safety.
- Optional for UC15 pump head, can fit for 4 different size tubing, large flow rate.
- Optional for UC20 pump head, can use medical dialysis tube, matching with medical dialysis equipment.

Typical Application

- Mainly for laboratory.

Roller Assembly

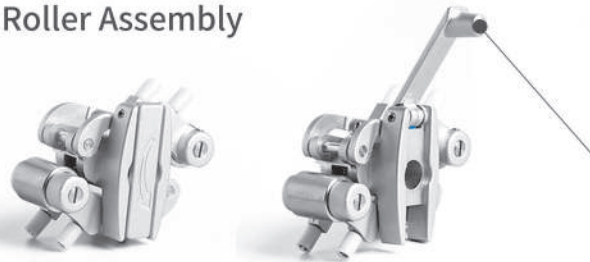

Manual lever help install the tube, and can finish liquid circulation when power down unexpectedly.

Tubing Installation Procedure



1. Press the pipe clamp, put the tube into the U shaped groove.

2. Put the tube between the two guide posts. Hold the spanner, rotate the wheel body.

3. Press the pipe clamp, put the tube into the U shaped groove.

4. Installation is finished.

Product Composition and Flow Rate Range

Model	Pump Head	Speed Range(rpm)	Tubing Size	Flow Rate (mL/min)
LabV3-IV	UC15	0.1-350	16"	0.1651-596
			15"	0.3440-1251
			17"	0.5818-2186
			18"	0.8652-3281
	UC20	0.1-200	Medical dialysis tube 8*2	0.7327-811



COMPACT LABORATORY PERISTALTIC PUMP

Compact Peristaltic Pump

LabK

3 YEARS WARRANTY

Three years warranty

ABS

ABS Plastic shell



- ABS engineering plastic housing, anti-corrosion, anti-static.
- OLED screen display motor speed, digital knob control speed.
- Compact design, various external control.
- Easy to observe the pump head and tubing working situation.
- Low power consumption, mute working.
- Stable flow rate and suitable for continuous dosing applications.
- Easy to replace long life PharMed tubing.
- Digital knob control speed, memory back up, user setting saved if power lost.

Dimension Drawing (Unit: mm)

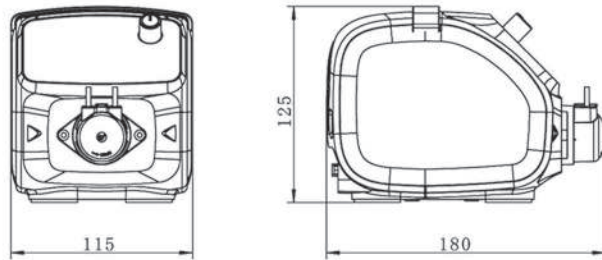

Color Selection



Technical Specifications

LabK			
Flow rate range	0.004-63.96mL/min	External control	Start/stop direction control (switch signal), 0-5V, 4-20mA (standard), 0-10V (optional)
Speed range	0.1-150rpm reversible		
Speed resolution	0.1rpm	Power adapter	Output: (12V/1A); Input: AC100V-240V, 50Hz/60Hz
Speed control	Digital knob		
Control method	Digital knob control and mechanical keypad	Dimension	180*115*125mm(L*W*H)
Keypad lifetime	300,000 times	Weight	0.8kg
Display	0.96" OLED display	Power consumption	<12W
Communication interface	USB connector, RS485 interface (MODBUS protocol, RTU mode)	Condition temperature	0-40°C
		Relative humidity	<80%,no condensation

Product Composition and Flow Rate Range

Model	Pump Head	Speed(rpm)	Tubing Size (ID×Wall Thickness)(mm)	Flow Rate Range (mL/min)
LabK	MicroPump	0.1-150	1*1	0.004-6.38
			2*1	0.014-21.45
			3*1	0.031-47.26
			4*1	0.042-63.96

Compact Peristaltic Pump

LabQ

3 YEARS WARRANTY

Three years warranty

ABS

ABS Plastic shell



- LabQ with ABS engineering plastic housing, 2.4 inch LCD display; small and compact, low power and ultra-silence.
- The digital knob is convenient for speed regulation and easy to operate.
- Multiple external control modes are optional, support RS485 communication, standard MODBUS protocol (RTU mode).
- Meet complex work environment with the super anti-interference and wide voltage design.
- Flow rate and motor speed display in the same screen.
- Super silent drive setting, precise control, low vibration and low noise.
- Mechanical keypad control, menu interface, convenient for users setting the parameters.
- Digital rotary knob is convenient for speed regulation and easy to operate.
- Various external control functions, support 0-5V, 0-10V, 4-20mA analog signals control speed.

Dimension Drawing (Unit: mm)

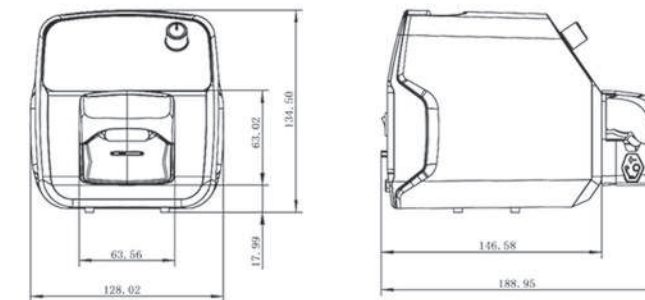

Technical Specifications

LabQ			
Flow rate range	0.0033-326.55mL/min	Start/stop, reversing signal	Switch signal(The default is passive signal, active signal is optional)
Speed range	0.1-350rpm		
Speed resolution	0.1rpm	Communication interface	RS485, (MODBUS protocol, RTU mode)
Control method	Digital knob control and mechanical keypad		
Display	2.4 inch LCD screen	Dimension	188*128*135mm(L*W*H)
External speed control	0-5V, 0-10V, 4-20mA	Weight	1.1kg
Output interface	Open-Collector output	Power consumption	<30W
Power supply	Output: 24V/1.25A	Temperature	0-40°C
	Input: AC100V-240V, 50Hz/60Hz	Relative humidity	<80%,no condensation

Product Composition and Flow Rate Range

Model	Channel number	Tubing	ID×Wall thickness(mm)	mL / r	Speed(rpm)	Flow Rate(mL/min)	Weight(kg)
LabQ/KT15	Single channel	13"	0.8×1.6	0.033	0.1~350	0.0033~11.55	1.1
		14"	1.6×1.6	0.156		0.0156~54.60	
		19"	2.4×1.6	0.286		0.0286~100.10	
		16"	3.1×1.6	0.477		0.0477~166.95	
		25"	4.8×1.6	0.933		0.0933~326.55	

Compact Peristaltic Pump

LabT

- 3 YEARS WARRANTY
Three years warranty
- ABS
ABS Plastic shell



- ABS engineering plastic housing, anti-corrosion, anti-static.
- OLED screen display motor speed, digital knob control speed.
- Compact design, various external control.
- Easy to observe the pump head and tubing working situation.
- Low power consumption, mute working.
- Stable flow rate and suitable for continuous dosing applications.
- Easy to replace long life PharMed tubing.
- Digital knob control speed, memory back up, user setting saved if power lost.

Dimension Drawing (Unit: mm)

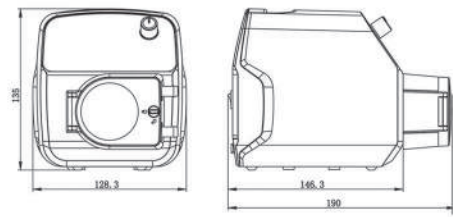

Suitable Pump Head

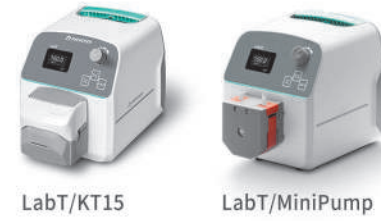

Technical Specifications

LabT			
Model	LabT/KT15 LabT/MiniPump LabT/UD15	Display	0.96" OLED display
Speed range	LabT/KT15: 0.1-350rpm LabT/MiniPump: 0.1-300rpm LabT/UD15: 0.1-350rpm	Power adapter	Output: 24V/1.25A; Input: AC100V-240V, 50Hz/60Hz
Speed resolution	0.1rpm	Communication interface	USB connector, RS485 interface (MODBUS protocol, RTU mode)
Control method	Digital knob control and mechanical keypad	Dimension	189*128*135mm(L*W*H)
External control	Start/stop direction control (switch signal), 0-5V, 4-20mA (standard), 0-10V (optional)	Weight	1100g
		Power consumption	< 30W
		Condition temperature	0-40°C
		Relative humidity	<80%,no condensation

Product Composition and Flow Rate Range

Model	Pump Head	Tubing		Speed (rpm)	Flow Rate (L/min)	Weight(kg)
		Tubing Sizes	IDxWall thickness(mm)			
LabT	UD15	16"	3.1x1.6	0.1-350	0.08-280	1.1
		25"	4.8x1.6		0.16-580	
		17"	6.4x1.6		0.26-930	
	KT15	13"	0.8x1.6	0.1-350	0.0033-11.55	1.1
		14"	1.6x1.6		0.0156-54.6	
		19"	2.4x1.6		0.0286-100.1	
		16"	3.1x1.6		0.0477-166.95	
		25"	4.8x1.6		0.0933-326.55	
	MiniPump01	13"	0.8x1.6	0.1-300	0.0024-8.28	1.1
		14"	1.6x1.6		0.0112-33.88	
		19"	2.4x1.6		0.0252-77.23	
		16"	3.1x1.6		0.0394-114.31	
		25"	4.8x1.6		0.0652-190.00	
		1x1	1x1		0.005-15.01	
		2x1	2x1		0.018-54.63	
		2.5x1	2.5x1		0.0256-76.84	
		3x1	3x1		0.0356-108.39	
		MiniPump02	1x1		1x1	
	2x1	2x1	0.018-54.63			
	2.5x1	2.5x1	0.0256-76.84			
		3x1		0.0356-108.39		

Compact Peristaltic Pump

ST-HandyPump

- 304
304 Stainless steel
- 3 YEARS WARRANTY
Three years warranty



- 304 stainless steel shell, resist corrosion. Can be stacked to use.
- Closed-loop stepper motor, compact structure, low noise, low vibration.
- OLED screen display working speed and status. Digital knob control speed, easy operation.
- Support RS232 and RS485 communication.
- Various external control interface.
- Wide voltage design, high versatility.

Model Number

- ST-HandyPump

Dimension Drawing (Unit: mm)

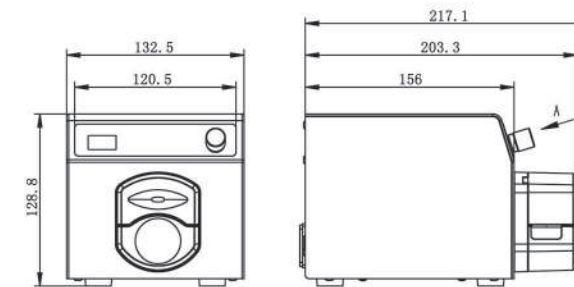

Suitable Pump Head

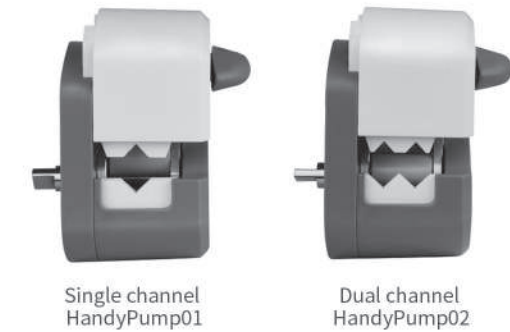

Technical Specifications

ST-HandyPump			
Flow rate range	0.0033~365.69mL/min	Power supply	AC100V-240V, 50Hz/60Hz
Speed range	0.1~300rpm	Communication interface	RS485, RS232
Speed resolution	0.1rpm	Output interface	Output motor working status
Control method	Digital knob control and mechanical keypad	Drive dimension	217.1*132.5*128.5mm(L*W*H)
Motor type	57 closed-loop stepper motor	Weight	2.92Kg
Keypad lifetime	300,000 times	Power consumption	≤75W
Display	OLED display(0.96")	Condition temperature	0-40°C
External control	Start/stop control(switch signal) Speed: 0-5V, 4-20mA(standard), 0-10V (optional)	Relative humidity	<80%,no condensation

Product Composition and Flow Rate Range

Model	Channel number	Pump Head	Speed(rpm)	Tubing Size	Flow Rate Range(mL/min)
ST-HandyPump	1/2	HandyPump01	0.1-300	13", 14", 19", 16", 25"	0.0033-365.69
		HandyPump02		13", 14", 19", 16"	0.0033-190.76



PUMP HEAD

KT15 AMC EasyPump
KD15/25 MiniPump UC15/20

Pump Head - EasyPump Series

EasyPump

Dimension Drawing(Unit: mm)

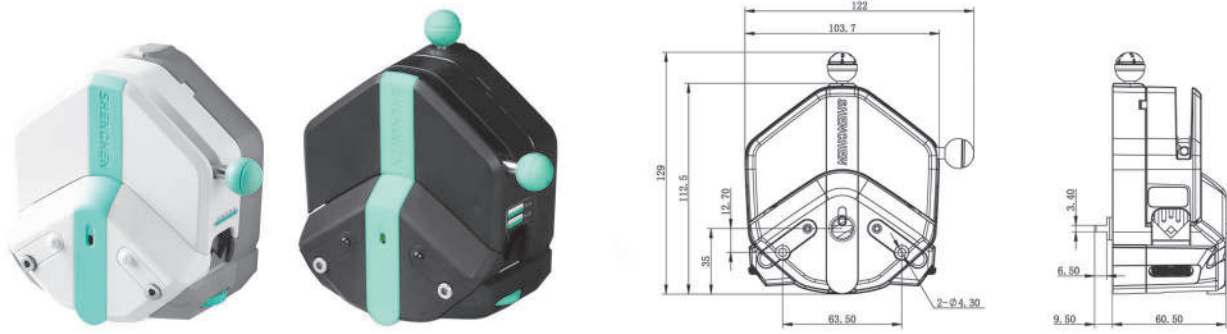

Pump Drive: **LabV-III** **LabF-III** **LabN-III** **LabM-III**

Easypump obtained U.S. Invention patent and Appearance patent.



Invention Patent No.: US 11,852,136 B2
Appearance patent No.: US D939,692 S

Easypump obtained EU Appearance patent.



Appearance patent No.: 008005789-0002

Flow Rate

Pump Head	Housing Material	Tubing		mL/r	Speed (rpm)	Flow Rate (mL/min)	Weight (kg)
		Size	IDxWall Thickness				
Single channel EasyPumpI/III	Engineering plastic	13#	0.8x1.6	0.053	0.1-600	0.0053-32	0.6
		14#	1.6x1.6	0.27		0.027-162	
		19#	2.4x1.6	0.55		0.055-330	
		16#	3.1x1.6	0.933		0.093-560	
		25#	4.8x1.6	1.967		0.197-1180	
		17#	6.4x1.6	3.333		0.333-2000	
Single channel EasyPumpII/IV	PPS	18#	7.9x1.6	4.3		0.430-2580	
		15#	4.8x2.4	1.8		0.180-1080	
		24#	6.4x2.4	2.733		0.273-1640	
		35#	7.9x2.4	3.833		0.383-2300	
Dual channel EasyPumpV/VI		36#	9.6x2.4	5.167		0.517-3100	
		13#	0.8x1.6	0.053		0.0053-32	
		14#	1.6x1.6	0.27	0.027-162		
		19#	2.4x1.6	0.55	0.055-330		
		16#	3.1x1.6	0.933	0.093-560		
		25#	4.8x1.6	1.967	0.197-1180		

Experimental conditions: Standard atmospheric pressure, room temperature at 20°C, the liquid is pure water, no pressure, no suction and lift.
Note: Actually, it is affected by many factors such as transmission medium, inlet and outlet pressure, hose material and error, working environment, etc. This data is for reference only.

Flow Rate(0.1-600rpm)

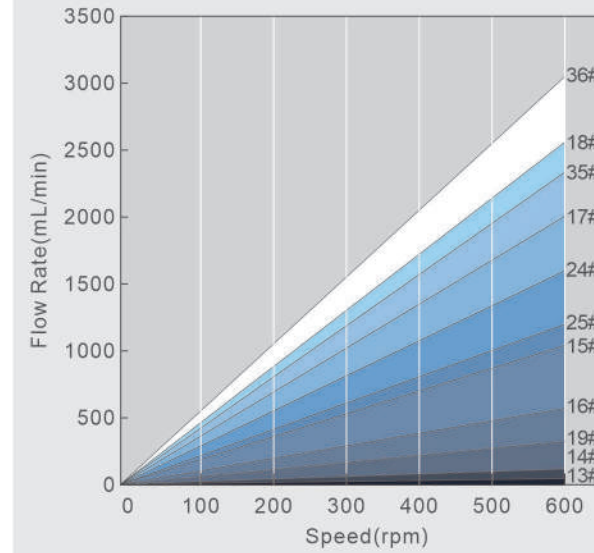

Pressure/Flow Rate Curve(100rpm)

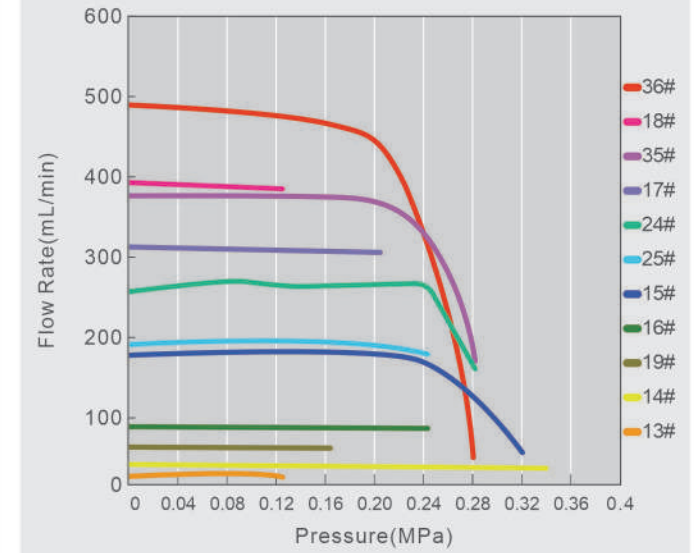

Filling Volume Reference Parameter

Drive	Pump Head	Tubing	Filling Volume(mL)	Filling Time(s)	Accuracy(±%)	Output (pcs/min)	Motor Speed (rpm)	
LabF6 Series	EasyPump	13"	0.4	1.2	0.8	27	377.36	
		13"	1	2.5	0.5	17	452.83	
		14"	2	1	0.5	30	444.44	
		19"	5	1.2	0.5	27	454.55	
		16"	7	1	0.5	30	450.16	
		25"	10	0.8	0.8	33	381.29	
		25"	15	1	0.5	30	457.55	
		25"	20	1.5	0.5	24	406.71	
		17"	30	1.2	0.5	27	450.05	
	2*EasyPump	18"	50	1.5	0.5	24	465.12	
		15"	15	1.2	0.5	27	416.67	
		24"	20	1.2	0.5	27	365.90	
		35"	30	1.2	0.5	27	391.34	
		36"	50	1.5	0.5	24	387.07	
		2*EasyPump	13"	0.5	0.8	0.8	33	353.77
			13"	1	1.2	0.5	27	471.70
			14"	2	0.6	1	38	370.37
			14"	5	1.5	0.5	24	370.37
19"	10		1.2	0.5	27	454.55		
16"	15		1.2	0.5	27	401.93		
2*EasyPump	16"	20	1.5	0.5	24	428.72		
	25"	30	1	0.5	30	457.55		
	17"	50	1	0.5	30	450.05		
	18"	70	1	0.5	30	488.37		
	15"	30	1.2	0.5	27	416.67		
	24"	50	1.2	0.5	27	457.37		
2*EasyPump	35"	70	1.2	0.5	27	456.56		
	36"	100	1.5	0.5	24	387.07		

Experimental conditions: Standard atmospheric pressure, room temperature at 20°C, the liquid is pure water, no pressure, no suction and lift.
Note: Actually, it is affected by many factors such as transmission medium, inlet and outlet pressure, hose material and error, working environment, etc. This data is for reference only.

Pump Head - AMC Series

AMC Series



Product Introduction

- The unique elastic positioning mechanism allows users to install and remove cartridge with one hand. Multichannel, small volume transferring.
- Elastic pressure tube design to extend the service life of the tube.
- Stepless adjustment of the tube pressure gap, effectively improving the accuracy between channels.
- 304 stainless steel roller assembly, including 6 rollers and 10 rollers structure, which are designed with low noise and high speed, suitable for supporting various analytical instruments.

AMC obtained EU Appearance patent.



Appearance patent No.: 008005789-0001

Pump Drive : LabV LabF LabN LabM

Typical Application

- Support blood sugar analytical device.
- Support ammonian analytical instrument.

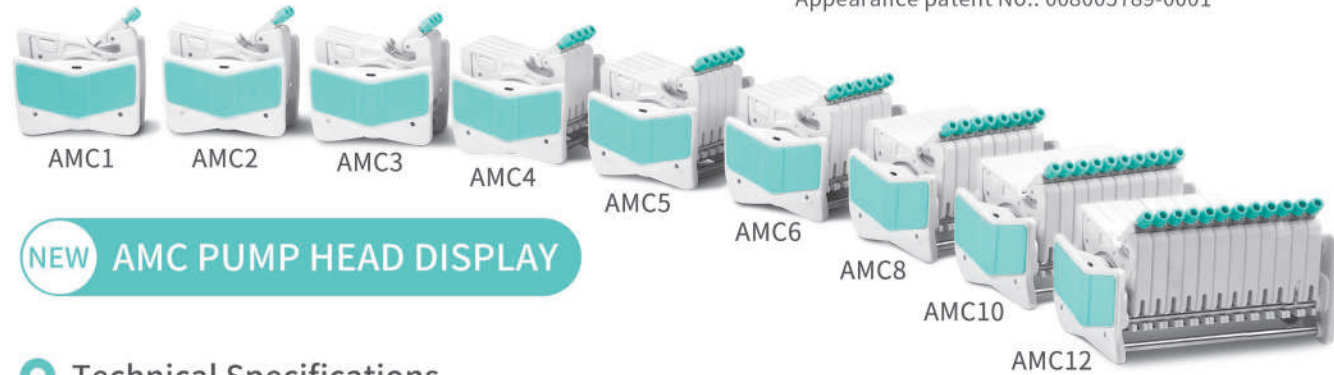

NEW AMC PUMP HEAD DISPLAY

Technical Specifications

Experimental conditions: Standard atmospheric pressure, room temperature at 20°C, the liquid is pure water, no pressure, no suction and lift.
Note: Actually, it is affected by many factors such as transmission medium, inlet and outlet pressure, hose material and error, working environment, etc. This data is for reference only.

Tubing	Speed	Flow rate of pump head with 10 rollers (mL/min)	Flow rate of pump head with 6 rollers (mL/min)	Tubing maximum pressure (Mpa)	
				Continuous	Intermittent
1×1	0.1~150rpm	0.0050~7.55	0.0062~9.36	0.1	0.1
2×1		0.0183~27.52	0.0220~33.06		
2.4×0.8		0.0254~38.13	0.0319~47.81		
3×1		0.0323~48.38	0.0434~65.17		
0.13×0.86		0.0002~0.29	0.0002~0.31		
0.19×0.86		0.0003~0.44	0.0003~0.46		
0.25×0.86		0.0005~0.76	0.0005~0.80		
0.51×0.86		0.0013~2.00	0.0014~2.05		
0.89×0.86		0.0030~4.47	0.0031~4.65		
1.14×0.86		0.0061~9.16	0.0065~9.74		
1.42×0.86		0.0125~18.75	0.0142~21.28		
2.06×0.86		0.0197~29.60	0.0234~35.17		
2.79×0.86	0.0286~42.86	0.0372~55.77			

Pump Head - KD Series

KD15/25



Dimension Drawing(Unit: mm)

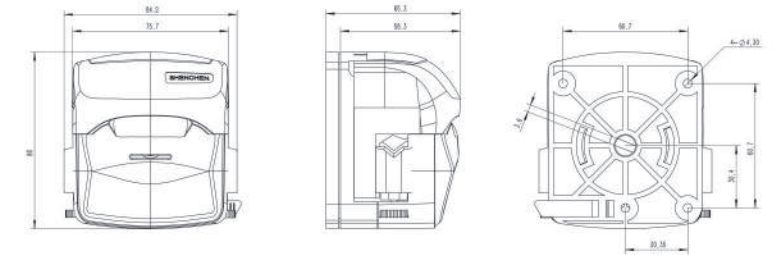

Pump Drive : LabV LabF LabN LabM

Pump Head	Housing Material	Flow Rate							
		Tubing		3 Rollers		4 Rollers		Speed (rpm)	Weight (kg)
		Size	IDxWall Thickness	(mL/r)	(mL/min)	(mL/r)	(mL/min)		
KD15	PPS	13#	0.8x1.6(mm)	0.06	0.006-36	0.06	0.006-36	0.1-600	0.6
		14#	1.6x1.6(mm)	0.26	0.026-156	0.25	0.025-150		
		19#	2.4x1.6(mm)	0.55	0.055-330	0.51	0.051-306		
		16#	3.1x1.6(mm)	0.92	0.092-552	0.88	0.088-528		
		25#	4.8x1.6(mm)	2.2	0.22-1320	1.9	0.19-1140		
		17#	6.4x1.6(mm)	3.6	0.36-2160	3	0.30-1800		
KD25		18#	7.9x1.6(mm)	5.4	0.54-3240	4.8	0.48-2880		
		15#	4.8x2.4(mm)	2.15	0.215-1290	1.9	0.19-1140		
		24#	6.4x2.4(mm)	3.47	0.347-2082	3.1	0.31-1860		

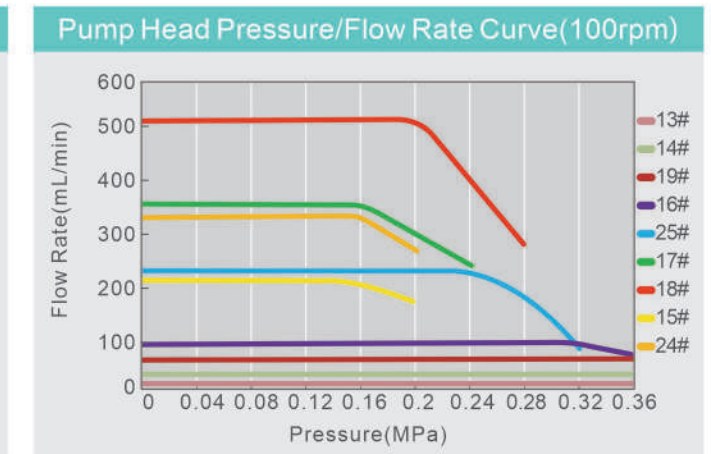
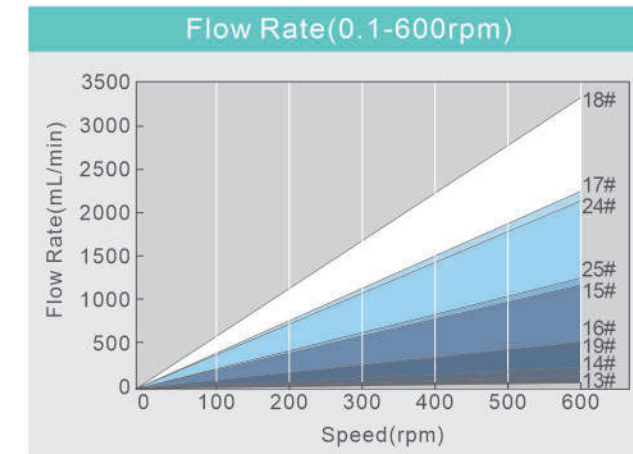

Filling Volume Reference Parameter						
Pump Head	Tubing	Filling Volume(mL)	Filling Time(s)	Accuracy(±%)	Output (pcs/min)	Motor Speed(rpm)
KD15	13#	0.1	0.5	0.8	40	200
	14#	1	1	0.5	30	230.8
	19#	3	1	0.5	30	327.3
	16#	7	1.5	0.5	24	304.3
	25#	10	1	0.5	30	272.7
	17#	30	1.5	0.5	24	333.3
KD25	18#	80	2.5	1	17	355.6
	15#	10	1.2	0.5	27	232.6
	24#	30	2	0.5	20	259.36

Experimental conditions: Standard atmospheric pressure, room temperature at 20°C, the liquid is pure water, no pressure, no suction and lift.
Note: Actually, it is affected by many factors such as transmission medium, inlet and outlet pressure, hose material and error, working environment, etc. This data is for reference only.

Pump Head - KT15

KT15



Product Introduction

Exquisite appearance, small size. The upper pressing block is opened by a turning method, and the operation is simple. The elastic upper block can reduce tubing wear. Quickly replace tubing with self-adaptive tube clamp. Suitable for 5 different sizes of tubes to meet different flow rate requirements.

Typical Application

- Medical equipment, biotechnology, pharmaceutical
- Chemical and food industries

Pump Drive : **LabQ** **LabT**

Dimension Drawing(Unit: mm)

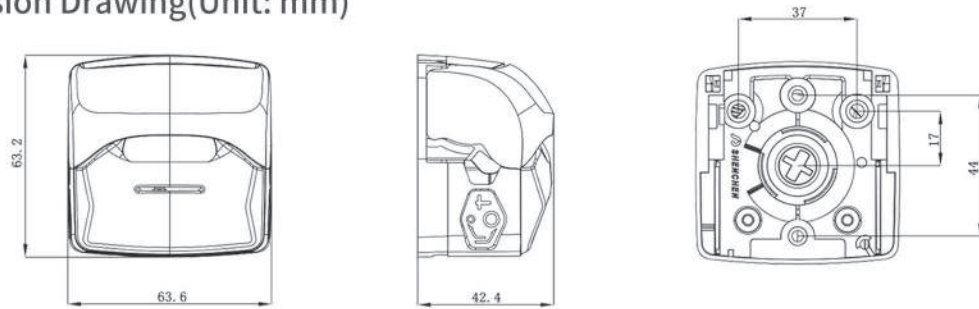

Tubing Installation Procedure

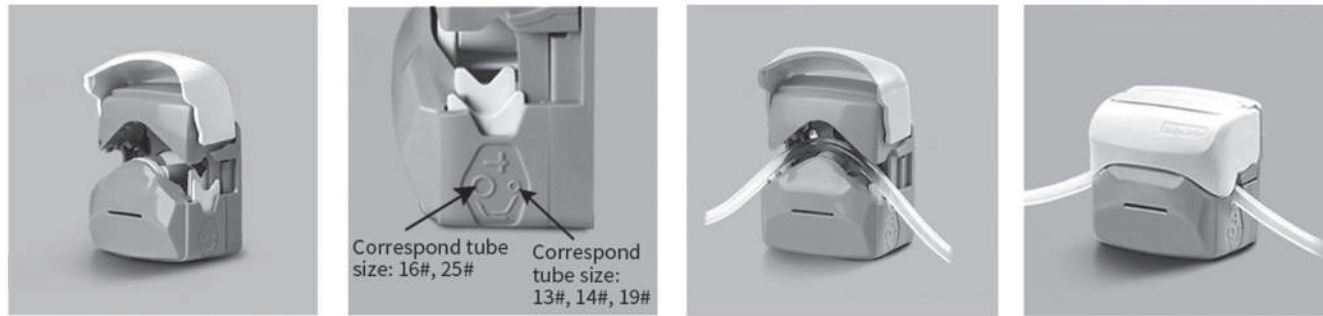

1. Lift the flip top of the pump head to open the pump head.

Correspond tube size: 16#, 25#
Correspond tube size: 13#, 14#, 19#

2. Adjust the tube holder to the position corresponding to the installed size.

3. Put the tubing into the pump head.

4. Close the flip top of the pump head to complete the installation.

Technical Specifications

Experimental conditions: Standard atmospheric pressure, room temperature at 20°C, the liquid is pure water, no pressure, no suction and lift.
Note: Actually, it is affected by many factors such as transmission medium, inlet and outlet pressure, hose material and error, working environment, etc. This data is for reference only.

Pump Head	Channel number	Tubing	ID×Wall thickness(mm)	mL / r	Speed(rpm)	Flow Rate(mL/min)	Weight(kg)
KT15	Single channel	13"	0.8×1.6	0.033	0.1~600	0.0033~19.97	0.096
		14"	1.6×1.6	0.156		0.0156~93.42	
		19"	2.4×1.6	0.286		0.0286~171.6	
		16"	3.1×1.6	0.477		0.0477~286.32	
		25"	4.8×1.6	0.933		0.0933~560.04	

Pump Head - HandyPump

HandyPump

Product Introduction

- Front knob to open the pump head, save space.
- Automatic tubing retention makes tube loading easy and quick.
- Single and dual-channel head available.
- 5 different sizes tubing to meet different flow rate requirements.



Single channel HandyPump01



Dual channel HandyPump02

Tubing Installation Procedure



1. Turn the knob anticlockwise 180°, open the upper block.

2. Put the tube between rollers and upper block, tighten up the tubing lightly.

3. Turn the knob clockwise 180°, put the upper block back to original position, fasten the tube.

Technical Specifications

Experimental conditions: Standard atmospheric pressure, room temperature at 20°C, the liquid is pure water, no pressure, no suction and lift.
Note: Actually, it is affected by many factors such as transmission medium, inlet and outlet pressure, hose material and error, working environment, etc. This data is for reference only.

Model	Channel number	Tubing	ID×Wall thickness(mm)	mL/r (3 rollers)	mL/r (6 rollers)	Speed (rpm)	Flow Rate(L/min) (3 rollers)	Flow Rate(L/min) (6 rollers)	Weight (kg)
HandyPump01	Single channel	13"	0.8×1.6	0.033	0.031	0.1~300	0.0033~10.03	0.0031~29.36	0.224 (3 rollers)
		14"	1.6×1.6	0.187	0.126		0.0187~56.09	0.0208~37.68	
		19"	2.4×1.6	0.371	0.215		0.0371~111.17	0.0036~64.51	
		16"	3.1×1.6	0.636	0.345		0.0636~190.76	0.0059~103.51	
		25"	4.8×1.6	1.219	0.636		0.1219~365.69	0.01038~190.81	0.302 (6 rollers)
HandyPump02	Dual channel	13"	0.8×1.6	0.033	—	0.1~300	0.0033~10.03	—	0.224 (3 rollers)
		14"	1.6×1.6	0.187	—		0.0187~56.09	—	
		19"	2.4×1.6	0.371	—		0.0371~111.17	—	
		16"	3.1×1.6	0.636	—		0.0636~190.76	—	

Pump Head - UC15/20

UC15/20

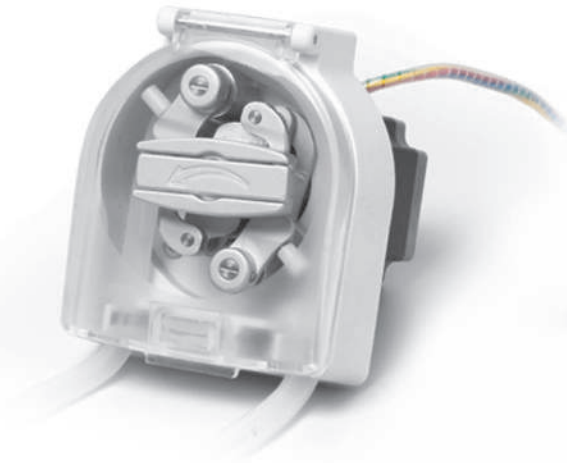

Roller Assembly

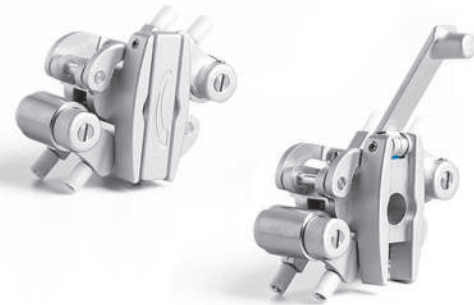

Pump Drive : LabV3-IV

Product Introduction

UC15/UC20 spring pump head is widely used for medical dialysis equipment. Transparent protective cover, can observe the working situation anytime; uncover signal output, stop working when uncover to ensure safety; Elastic roller assembly, running smoothly; manual lever help install the tube, and can finish liquid circulation when power down unexpectedly; support stepper motor ,DC motor.

Dimension Drawing(Unit:mm)

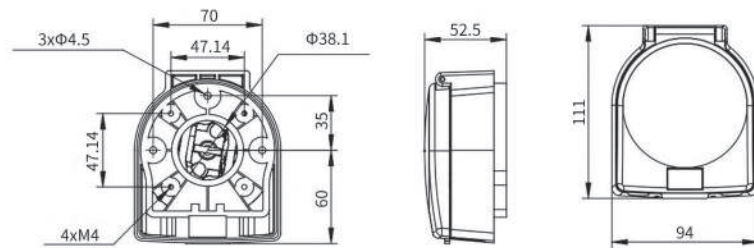

Tubing Installation Procedure



1. Press the pipe clamp, put the tube into the U shaped groove.
2. Put the tube between the two guide posts. Hold the spanner, rotate the wheel body.
3. Press the pipe clamp, put the tube into the U shaped groove.
4. Installation is finished.

Technical Specifications

Model	Housing Material		Rollers assemble construction	Tubing		Speed Range (rpm)	Flow Rate (mL/min)	Weight(kg)
	Base	Protecting cover		Size	ID×Wall(mm)			
UC15	PSF	PC	Spring-like structure	16"	3.1×1.6	0.1-350	0.1651-596	1.37
				25"	4.8×1.6		0.3440-1251	
				17"	6.4×1.6		0.5818-2186	
				18"	7.9×1.6		0.8652-3281	
UC20	PSF	PC	Spring-like structure	Medical dialysis tube	8×2	0.1-200	0.7327-811	1.37

Pump Head - MiniPump

MiniPump



Product Introduction

Minipump series products which adopt compact and embedded design are more suitable for supporting a variety of instruments and equipments. Single and dual channel are optional. It accepts 8 kinds of tubing. Flow rates are 0.0024-190 mL/min. PharMed BPT long-life tubing from French Saint-Gobain is installed in internal part of pump head. Applicable motors for Minipump are stepper motor, DC motor, AC motor and other modes to drive with wide applications.

Material: PVDF

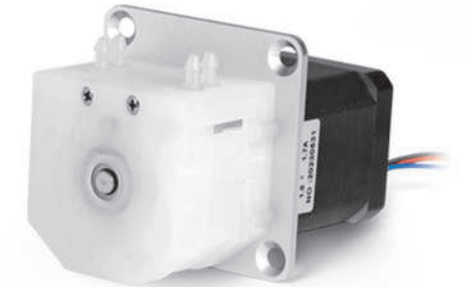

Pump Drive : LabT

Dimension Drawing(Unit: mm)

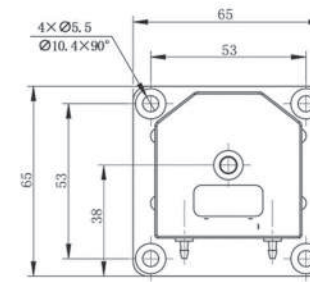

Tubing Installation Procedure



1. Make the two tubing clamps align the slide way of pump head two sides.
2. Ensure that the tubing is in the middle of rollers, and push the clamps into the pump head.
3. Make the compression block align the upper slide way of pump head.
4. Press the compression block into the pump head, and ensure it fixed.

Technical Specifications

Experimental conditions: Standard atmospheric pressure, room temperature at 20°C, the liquid is pure water, no pressure, no suction and lift. Note: Actually, it is affected by many factors such as transmission medium, inlet and outlet pressure, hose material and error, working environment, etc. This data is for reference only.

Pump Head	Tubing	ID×Wall(thickness(mm))	mL/r	Speed (rpm)	Flow Rate (mL/min)
MiniPump01	13"	0.8×1.6	0.024	0.1~300	0.0024-8.28
	14"	1.6×1.6	0.112		0.0112-33.88
	19"	2.4×1.6	0.252		0.0252-77.23
	16"	3.1×1.6	0.394		0.0394-114.31
	25"	4.8×1.6	0.652		0.0652-190.00
	1×1	1×1	0.05		0.005-15.01
	2×1	2×1	0.18		0.018-54.63
	2.5×1	2.5×1	0.256		0.0256-76.84
MiniPump02	3×1	3×1	0.356	0.1~300	0.0356-108.39
	1×1	1×1	0.05		0.005-15.01
	2×1	2×1	0.18		0.018-54.63
	2.5×1	2.5×1	0.256		0.0256-76.84
	3×1	3×1	0.356		0.0356-108.39

Pump Head - MicroPump

MicroPump



Product Introduction

Beautiful appearance, compact size, variety colors to choose, OEM ideal choice, can be driven by stepper motor, DC motor etc.

Dimension Drawing (Unit: mm)

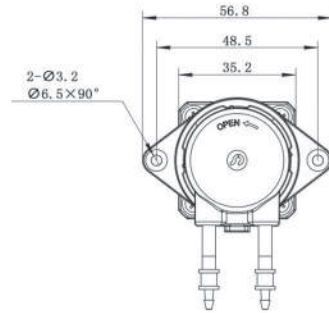

Pump Drive : LabK

Tubing Installation Procedure



Technical Specifications

Experimental conditions: Standard atmospheric pressure, room temperature at 20°C, the liquid is pure water, no pressure, no suction and lift.
Note: Actually, it is affected by many factors such as transmission medium, inlet and outlet pressure, hose material and error, working environment, etc. This data is for reference only.

Flow model selection						
Tubing No.		B04	B06	B10	B22	
Tubing ID. (wall thickness 1mm)		1.0*1.1	2.0*1.0	3.0*1.0	4.0*1.0	
Tubing material		PharMed BPT	PharMed BPT	PharMed BPT	PharMed BPT	
Flow rate (mL/min)	24V Brush/Brushless HA/HD	Single gear	14.88	50.05	110.27	149.23
		Double gear	1.28	4.29	9.45	12.79
	12V Brush/Brushless HB/HE	Single gear	14.88	50.05	110.27	149.23
		Double gear	1.28	4.29	9.45	12.79
	6V Brush/Brushless HC/HF	Single gear	14.88	50.05	110.27	149.23
		Double gear	1.28	4.29	9.45	12.79
	35 Stepper motor (350rpm) STB		14.88	50.05	110.27	—
	42 Stepper motor (350rpm) STA		14.88	50.05	110.27	149.23

Peristaltic Pump Tubing

Silicone Tubing

Platinum-cured silicone tubing: Soft, slightly transparent, smooth inner wall; low protein adhesion, low protein penetration, temperature range: -51~238°C.





Micro Flow Rate Tubing										
Tubing Size	0.13×0.86	0.5×0.86	0.86×0.86	1.52×0.86	2.06×0.86	2.79×0.86	1×1	2×1	3×1	2.4×0.8
Tubing cross sections (1:1)										
Wall thickness (mm)	0.86						1.0		0.8	
Inside diameter (mm)	0.13	0.5	0.86	1.52	2.06	2.79	1.0	2.0	3.0	2.4
Maximum pressure (Mpa)	Continuous					0.1				
	Intermittent					0.1				

Basic Flow Rate Tubing																	
Tubing Size	13"	14"	19"	16"	25"	17"	18"	15"	24"	35"	36"						
Tubing cross sections (1:1)																	
Wall thickness	mm						1.6			2.4							
	inch						1/16			3/32							
Inside diameter	mm						0.8	1.6	2.4	3.2	4.8	6.4	7.9	4.8	6.4	7.9	9.6
	inch						1/32	1/16	3/32	1/8	3/16	1/4	5/16	3/16	1/4	5/16	3/8
Maximum pressure (Mpa)	Continuous			0.17			0.14	0.1	0.07	0.17			0.14				
	Intermittent			0.27			0.24	0.14	0.1	0.27			0.24				



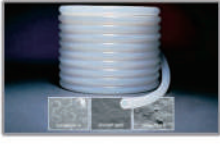

Industrial Tubing										
Tubing Size	26"	73"	82"	86"	90"	88"	92"			
Tubing cross sections (1:1)										
Wall thickness	mm			3.3		6.4				
	inch			1/8		1/4				
Inside diameter	mm			6.4	9.6	12.7	9.5	19	12.7	25.4
	inch			1/4	3/8	1/2	3/8	3/4	1/2	1
Maximum pressure (Mpa)	Continuous				0.2			0.25		
	Intermittent				0.27			0.3		

Peristaltic Pump Tubing

SAINT-GOBAIN Tubing : Tygon, PharMed BPT, Norprene etc

	A Tygon3350	B Tygon E-3603	C Norprene Chemical	D PharMed	E Norprene A-60-F
					
Formulation	Tygon3350	Tygon R-3603	Norprene Chemical	PharMed	Norprene A-60-F
Application	Pharmaceutical, cosmetic, medical and auto-analysis application.	General laboratory, food & beverage, biopharmaceutical, analytical instruments.	Excellent for chemical processing and general industrial applications. Food and beverage applications where extractables are a concern.	Cell and tissue culture work and pharmaceutical uses. Also good for light-sensitive samples.	Ideal for the food, dairy and beverage.
Advantages	Ultra-smooth; minimizes bacterial growth. Good for mild to medium concentration bases, salts and alcohols; odorless, tasteless, and nontoxic. Transparent.	Inexpensive tubing for general lab application. Nonaging, nonoxidizing. Clear for easy flow monitoring. Handles virtually all inorganic chemicals. Low gas permeability. Smooth bore; good for viscous fluids. High dielectric constant.	Norprene thermoplastic elastomer outer jacket with chemically inert Tygon® 2075 inner bore for excellent chemical resistance. Plasticizer-free to guard against extractables. Long flex life. Opaque beige.	Great for tissue and cell work-nontoxic and nonhemolytic; long service life minimizes risk of fluid exposure; reduces tubing costs and pump downtime. Opaque to UV and visible light to protect light-sensitive fluids. Heat sealable, bondable, and formable. Extremely low gas permeability.	Heat, ozone, and UV light resistant. Nonaging; nonoxidizing; superior acid and alkali resistance. Opaque beige.
Application Suitability	_____	ACIDS GOOD ALKALIES GOOD ORGANIC SOLVENTS NO PRESSURE GOOD VACUUM GOOD VISCIOUS FLUIDS EXCELLENT STERILE FLUIDS GOOD	_____	ACIDS GOOD ALKALIES GOOD ORGANIC SOLVENTS NO PRESSURE GOOD VACUUM EXCELLENT VISCIOUS FLUIDS GOOD STERILE FLUIDS EXCELLENT	_____
Physical characteristics	_____	Thermoplastic. PVC-based material with plasticizer. Firm (stiff) material. Transparent, clear.	_____	Thermoplastic elastomer. Polypropylene-based material with USP mineral oil. Excellent tensile strength. Firm (stiff) material. Opaque, beige.	_____
Temp.range	-75 to 450° F (-60-232° C)	-58 to 165° F (-50-74° C)	-76 to 165° F (-60-74° C)	-60 to 270° F (-59-135° C)	-60 to 275° F (-51-135° C)
Meets classifications	FDA 21 CFR 177.2600 USP Class VI EP 3.1.9. Exceeds 3A standards Manufactured according to GMP.	FDA 21 CFR 175.300	None.	None.	FDA 21 CFR 177.2600 NSF listed (Standard 51) Manufactured according to GMP.
Cleaning/ Sterilization	Ethylene oxide gamma irradiation, or autoclave for 30 min, 15psi (1 bar).	Unaffected by commercial sanitizers (with recommended procedures) Sterilize with ethylene oxide (ETO) or autoclave. To autoclave: Coil loosely in nonlinting cloth or paper, autoclave at 121°C (250°F). 1KG/cm ² (15psi) for 30 minutes (tubing will appear milky); air dry at max 66°C (150°F) for 2 to 2 ½ hours until clear.	Sterilize with ethylene oxide(ETO), autoclave or gamma irradiation up to 2.5Mrad. Repeated autoclaving will not affect overall life.	Autoclave, ethylene oxide, or gamma irradiation.	Autoclave.

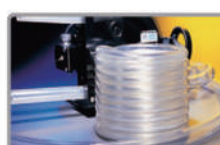
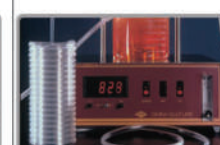
Peristaltic Pump Tubing

	F Norprene A-60-G	G Tygon F-4040-A	H Tygon LFL	I TYGON 2475	K Viton
					
Formulation	Norprene A-60-G	Tygon F-4040-A	Tygon LFL	TYGON 2475	Viton
Application	For applications requiring excellent chemical, heat, ozone, and ultraviolet (UV) light resistance.	Fuels and industrial lubricants-gasoline, kerosene, heating oils, cutting compounds, and glycol-based coolants. Resists most hydrocarbons.	General laboratory use, provides longer life with peristaltic tubing pumps.	Sensitive fluid transfer applications requiring high purity.	Acid and solvent transfer, high-temperature.
Advantages	Best choice for vacuum/pressure applications. Offers longest life with good flow consistency. Heat and ambient ozone resistant. Good resistance to acids/alkalies. Black color hides dirt and dust. Heat sealable, nonaging, and nonoxidizing. High dielectric constant.	Resists embrittlement and swelling, ozone-and UV-resistant, with low-extractability. Translucent yellow.	Longest life of all Tygon® peristaltic tubing (1000hrs). Nonaging, nonoxidizing. Clear for easy flow monitoring. Broad chemical resistance; low gas permeability. Smooth bore. Good for viscous fluids. High dielectric constant.	Plasticizer free, smooth inner surface (inhibits particulate buildup and bacterial growth), safely disposed of through incineration and nontoxic. Transparent.	The most chemical resistant tubing. Registant to corrosives, solvents, and oils at elevated temperatures. Low gas permeability.
Application Suitability	ACIDS GOOD ALKALIES GOOD ORGANIC SOLVENTS NO PRESSURE EXCELLENT VACUUM EXCELLENT VISCIOUS FLUIDS EXCELLENT STERILE FLUIDS NO	_____	ACIDS GOOD ALKALIES GOOD ORGANIC SOLVENTS NO PRESSURE GOOD VACUUM GOOD VISCIOUS FLUIDS EXCELLENT STERILE FLUIDS POOR	_____	ACIDS EXCELLENT ALKALIES EXCELLENT ORGANIC SOLVENTS EXCELLENT PRESSURE GOOD VACUUM GOOD VISCIOUS FLUIDS GOOD STERILE FLUIDS FAIR
Physical characteristics	Thermoplastic elastomer. Polypropylene-based material with USP mineral oil. Excellent tensile strength. Firm (stiff) material. Opaque, black. Manufactured according to GMP.	_____	Thermoplastic. PVC-based material with plasticizer. Firm (stiff) material. Transparent, clear.	_____	Thermal set rubber. Viton B (67% fluorine) Firm (stiff) material. Opaque, black. Manufactured according to GMP.
Temp.range	-60 to 270° F (-59-135° C)	-35 to 165° F (-37-74° C)	-58 to 165° F (-50-74° C)	-94 to 125° F (-70-52° C)	-25 to 400° F (-32-205° C)
Meets classifications	None.	Meets NSF-51 and 3A sanitary standards.	USP Class VI, FDA 21 CFR 175.300	FDA 21 CFR 177.1520, USP 23 Class VI, Manufactured according to GMP.	None.
Cleaning/ Sterilization	Sterilize by autoclave only.	Not recommended.	Sterilize by ETO/autoclave. Coil loosely in nonlinting cloth or paper; autoclave at 250°F(121°C), 15 psi (1kg/cm ²), 30 minutes (tubing will appear milky); air dry at max 150°F (66°C) for 2 to 2 ½ hrs until clear.	Ethylene oxide or gamma irradiation.	Sterilization is not recommended.

Peristaltic Pump Accessories

A Filling Nozzle

Name	Material	Picture
Reducer anti-splash filling nozzle	SS316	
Flat filling nozzle	SS304/316	

B One Way Checkvalve



Avoid liquid drop off after filling and transferring.

C Filling Countersunk



Used for the output of tube, preventing the tube floating or absorbing the wall of container.

Name	Material	Tube
Counter sunk	304/316 stainless steel	13", 14", 19", 16", 25", 17", 18", 15", 24", 35", 36", 26", 73", 82"

D Fluid Pulse Damper

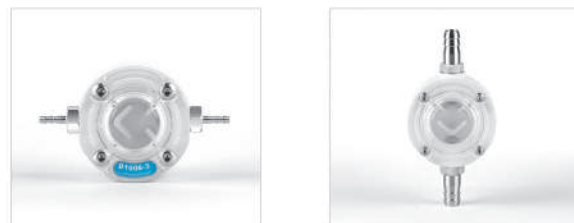









Special design for peristaltic pump, effectively suppress the peristaltic pump pulsation and improve the flow rate accuracy. The pulsation suppression rate can reach more than 95%.

Handling Dispenser Patent No: ZL201830096683.4; ZL201820353029.1

E Handling Dispenser



Filling nozzle and tubing cap			
Filling nozzle size	13"	14"	19"
Inner diameter	3mm	3.5mm	4.5mm
Picture			
Filling nozzle size	16"	15"/25"	17"/24"
Inner diameter	5mm	7mm	9mm
Picture			
Tubing size	17"	18"	Plum blossom cap
Inner diameter	9.6mm	11.1mm	
Picture			

Based on ergonomics design, elegant appearance, grip feeling comfortable, easy operation. Connect to peristaltic pump external control interface, with start/stop and full speed control, can realize transferring and dispensing function. Power supply and working indicator, show the dispenser working status. With hanging hole, can be hang up when do not use.

F Foot Pedal Switch



Control the pump start/stop with foot pedal switch.

Peristaltic Pump Accessories

G Tube Connector

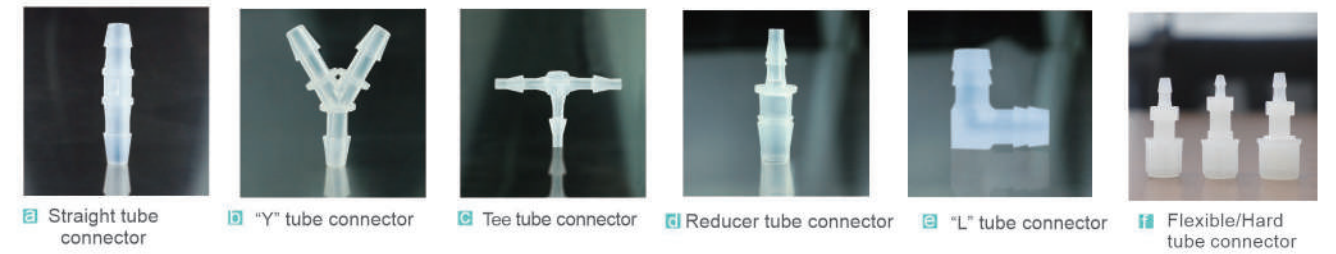

H PH Controller



Work with peristaltic pump, can control the liquid PH value, add acid or alkali automatically.
Function:
1. Liquid: Acid-Base Solutions
2. PH value : 0-14PH
3. Set up target PH value
4. Add acid or alkali liquid automaticall
5. Control: RS485 , 4-20mA
6. Power supply: DC24V (AC220V for option)
7. Suitable temperature: 0-60°C

I 5V Sensor



When applied in the dispensing line, it can detect whether there is a filling bottle in the production line. When the bottle approaches the sensor side, the switch action will be made without any mechanical contact or pressure, thereby providing a filling control order to the pump. In the same way, when no filling bottle is detected, the stop filling control order is provided to the pump.

J Benchtop Tubing Cutter



Stainless steel blade, makes right-angle cuts in several sizes of plastic tubing.

K Support Stand



The multiple filling stand is suitable for more than 2 channels filling. It can hold 2-8 filling nozzles. We can customize the suitable one according to your request.