

INTEGRA® 64

Automatic canister filling machine

More efficiency and availability. The automatic canister filling machine INTEGRA® 64 comes with the entire system. Preferred arrangement of the conveyor system is the U-shape, offering the economic operation by only one operator who feeds empty canisters and caps or plugs and afterwards palletizes the exactly filled and closed canisters, without changing his position.

BENEFITS

- Completely automatic filling with closing unit
- Convenient arrangement in U-shape
- High variation of different can sizes
- Huge variety of accessories
- Touch panel with integrated scale terminal as operating interface
- Stainless steel and acid protection design available

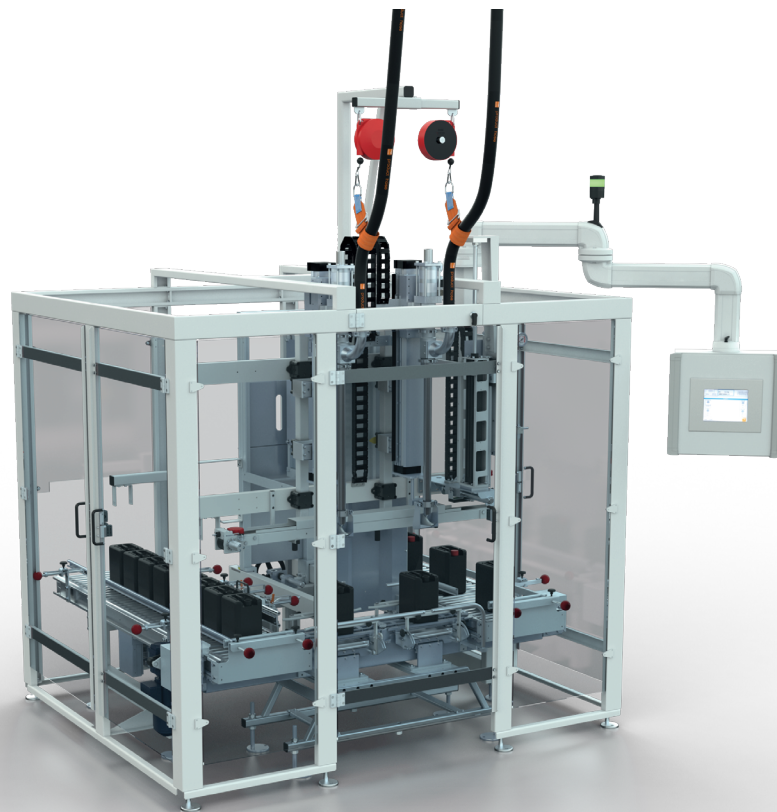

TECHNICAL DATA

Below-surface		64.1-1-P0	64.1-1-PA	64.1-1-PC	64.1-2-P0
Below-bunghole		64.2-1-P0	64.2-1-PA	64.2-1-PC	64.2-2-P0
Below-bunghole / Product Flow Control		64.5-1-P0	64.5-1-PA	64.5-1-PC	64.5-2-P0
Working cycle		positioning/ filling	positioning -filling/ lid placer	positioning -filling/ lid crimper	positioning/ filling product A/B
Air consumption [NI/cycle]	.1	50	50	50	50
	.2	30	30	30	30
	.5	35	35	35	35

INTEGRA[®] 64

Automatic canister filling machine

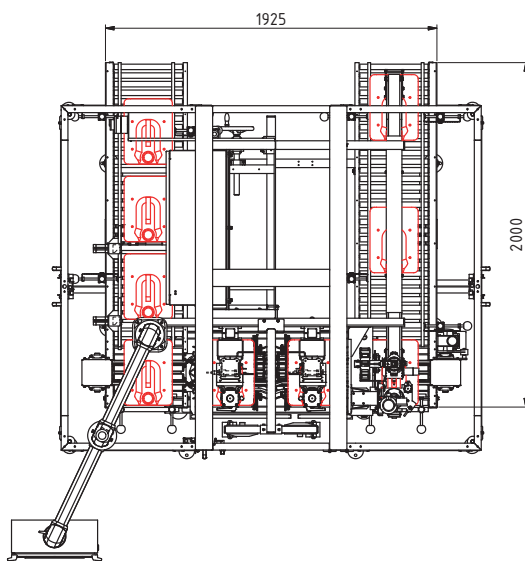
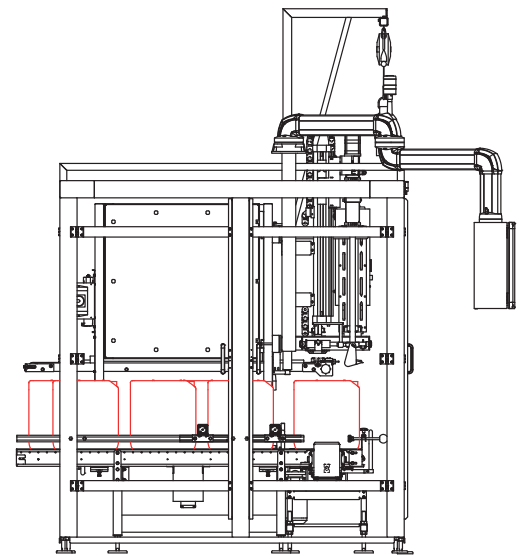
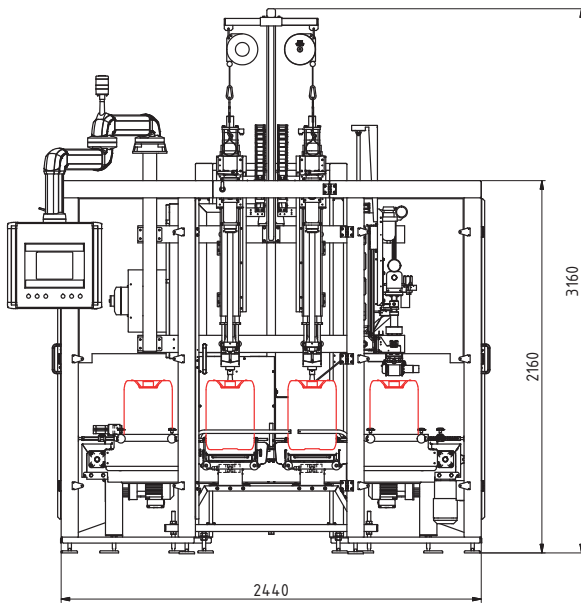

Configuration example

TECHNICAL DATA

ATEX design	II 2G c IIB T3
Electrical design	3x400V/N/PE, 50 Hz, 5kVA
Weighing range	0.5 kg to 15 kg, increment 0.005 kg, to 30 kg, incr. 0.01 kg, to 40 kg, increment 0.02 kg
External control	2 dry contacts or 4-20 mA signal for controlling an on-site pump or a pilot valve for coarse/fine fill
Can heights	100-400 mm
Required air pressure	5 bars dynamic
Weight	approx. 1,500 kg, without accessories
Ambient temperature	5-35°C
Product temperature	0-130°C
Nominal output	120 - 240 cans/hour