



PRODUCT & TECHNICAL SHOWCASE

PCI Membranes (a Filtration Group brand)
Unit 11, Victory Park, Solent Way
Whiteley, Fareham, PO15 7FN, United Kingdom

Tel: +44 (0)1489 563470
Email: pcimembranes@filtrationgroup.com

www.filtrationgroup.com

Filtration & Membrane Specialists



TABLE OF CONTENTS

WHAT AND WHERE

.....

A Series

A5 Series Ultrafiltration Modules	4-7
A19 Series Ultrafiltration Modules	8-11
A37 Series Ultrafiltration Modules	12-15

.....

B Series

B1 Series UF, NF & RO modules	16-19
B1 Series UF, NF & RO modules - <i>Series Flow (RO) Arrangement</i>	20-21
B1 Series Ultrafiltration modules - <i>Twin Entry Arrangement B1</i>	22-23
Series Ultrafiltration modules - <i>Parallel Flow Arrangement</i>	24-25

.....

C Series

C10 Series - Ultrafiltration & Nanofiltration modules	26-29
---	-------

.....

Test Modules

Micro 240 & 960 Series - Short-term RO, NF & UF Evaluation Modules	30-33
A5 Mini Module - Ultrafiltration Test Modules	34-37
Pilot Units - Pilot Scale Production and Processing	38-41
Tubular Membranes - Filtration Solutions	42-47

.....

Case Studies

<u>Wastewater Treatment</u>	52-53
Ultra-compact wastewater plant for 'Venice's garden' <i>A37 Series modules and membranes</i>	
<u>Landfill Leachate</u>	54-55
Multi-stage Treatment of Landfill Leachate. <i>B1 and A19/37 modules with AFC99 and FPA20 membranes</i>	
<u>Tomato Juice Concentration</u>	58-59
<i>B1 Series modules and & AFC99 membranes</i>	
<u>Effluent Treatment Plant</u>	60-62
The world's largest tubular membrane effluent treatment plant <i>B1 Series modules and ES404 (softwood) & ES625 (hardwood) membranes</i>	
<u>The Fyne Process</u>	66-67
Solution for rural water supplies with difficult sources <i>C10 Series tubular membranes</i>	
<u>Achnasheen Water Treatment Works</u>	68-69
Solution for rural water supplies with difficult sources <i>C10 Series tubular membranes</i>	
<u>Out Skerries Water Supply Plant</u>	70-72
Solution for rural water supplies with difficult sources <i>C10 Series tubular membranes</i>	

.....

PCI MEMBRANES

A HISTORY AND INTRODUCTION

An Introduction

As a specialist filtration and separation company, specialising in custom built crossflow membrane filtration systems for liquid separation in the process industries, we have prided ourselves on making our own membranes since the beginning.

Our customers demand the best that our technical and engineering skills and experience have to offer. It is our ability to interrogate problems and provide comprehensive solutions, delivering consistently impressive results that sets us apart from our competitors.

Over 45 years, we have built up an enviable reputation around our engineering capability, high quality products, reliability and solution led approach. Whereby today we can offer process solutions using Ultrafiltration, Nanofiltration, Microfiltration, and Reverse Osmosis technologies for a wide variety of applications including;

- Wastewater
- Chemical Industries
- MBR
- Pharmaceutical and Biotechnology
- Food & Beverage
- Drinking Water

A History

In 1968 a joint venture was set up between Portals Ltd and the UK Atomic Energy Authority to develop Reverse Osmosis systems for the desalination of sea water. Two types of system were developed in parallel. The first system was based on bundles of rods coated on the outside with membrane, whereas the second system used what is now the B1 tubular membrane system. Both systems proved unsuitable for desalination, but the tubular system proved to be well suited to applications involving feed solutions with high levels of suspended solids.

Originally known as Paterson Candy International (PCI) in 1986 we became the stand alone business known as **PCI Membranes**. Portals Ltd sold the PCI Membrane business to Thames Water in 1989 and in 1999 Thames Water acquired Memtech, a membrane business based in Swansea Wales, and integrating it.

View of valley in Eigg Island, Scotland.
Home to one of our Fyne Process Sites.

The image shows a large industrial facility with a high ceiling and skylights. In the foreground, there are several rows of stainless steel spiral-wound filtration modules. To the left, a large blue electric motor is mounted on a base. In the background, there are racks of white cylindrical components and various pipes and valves. A semi-transparent blue box is overlaid on the left side of the image, containing text.

A5 SERIES

FILTRATION PROCESSING

FOOD PROCESSING

APPLICATIONS

BEVERAGE PROCESSING

APPLICATIONS

WASTEWATER / EFFLUENT
SEPARATIONS

A5 SERIES

ULTRAFILTRATION MODULES

PCI Membranes compact A5 tubular ultrafiltration module can be used for a wide range of industrial applications in the process industry for the economic concentration and clarification of process liquids and wastewaters.

The module comprises of a replaceable core of 69 tubes of 6mm diameter and uses PCI's robust PVDF membranes which are suited to a variety of different process conditions. Cores are fitted into PCI's proven stainless steel housings giving a nominal total of 5m² of membrane area per 3.66m length module. (Shorter lengths are available).

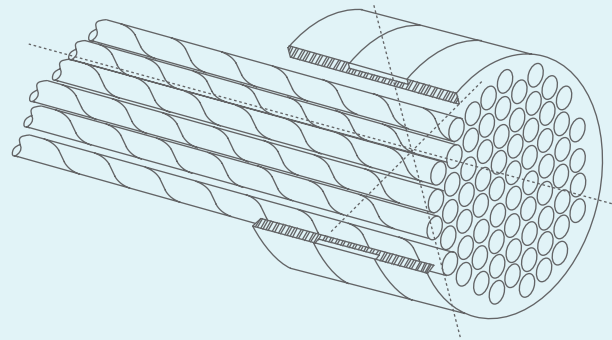

The open channel design processes liquids with high levels of suspended solids and facilitates highly effective cleaning in place.

The compact design gives the module a high strength allowing operating pressures of 10 bar. PCI's unique in-situ replaceable core enables fast, easy and cost effective remembraning.

"ULTRAFILTRATION (UF) IS A VARIETY OF MEMBRANE FILTRATION IN WHICH HYDROSTATIC PRESSURE FORCES A LIQUID AGAINST A SEMIPERMEABLE MEMBRANE. SUSPENDED SOLIDS AND SOLUTES OF HIGH MOLECULAR WEIGHT ARE RETAINED, WHILE WATER AND LOW MOLECULAR WEIGHT SOLUTES PASS THROUGH THE MEMBRANE. THIS SEPARATION PROCESS IS USED IN INDUSTRY AND RESEARCH FOR PURIFYING AND CONCENTRATING MACROMOLECULAR SOLUTIONS, ESPECIALLY PROTEIN SOLUTIONS. ULTRAFILTRATION IS APPLIED IN CROSS-FLOW AND SEPARATION IN ULTRAFILTRATION UNDERGOES CONCENTRATION POLARIZATION."



- **REPLACEABLE MEMBRANE CORE**
Allows fast, cost-effective remembraning, reducing downtime
- **PROVEN MEMBRANES**
With applications in the food, beverage, chemical and pharmaceutical industries
- **COMPACT MODULE DESIGN**
Quick and easy plant construction
- **TUBULAR MODULE**
Minimal prefiltration required, suited to liquids and high levels of suspended solids

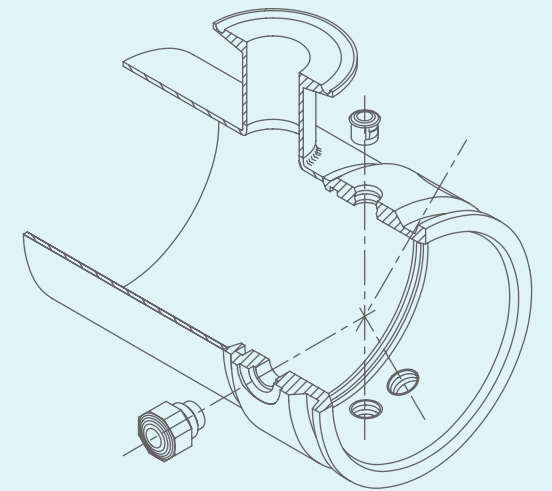

Dimensions			
Length (m)	1.83	3.05	3.66
Membrane Area (m ²)	2.04	3.97	4.76

Connections	
Permeate	1" tri-clamp or 3/4" 90° Spigot in AISI 316SS
Feed	3" tri-clamp in AISI 316SS

Additional Details	
Operating Pressure	Up to 10 bar max
Operating Temperature	Up to 60°C
Shroud Material	AISI 316 Stainless Steel
Membrane Type	PVDF
pH Range	1.5-10.5



A19 SERIES

FILTRATION PROCESSING

BEVERAGE PROCESSING
APPLICATIONS

BIOMASS SEPARATION /
CONCENTRATION

WASTEWATER / EFFLUENT
SEPARATIONS / CONCENTRATION
(WITHIN MBR)

A19 SERIES

ULTRAFILTRATION MODULES

The A19 tubular UF system incorporates a robust, low-cost module in stainless steel, together with a choice of tubular membranes in various materials. The removable core design (RCM) permits simple, rapid, and inexpensive membrane replacement.

Modules are offered in two lengths (3.05m & 3.66m), each housing 19 membranes, 12.5mm in diameter, cast in epoxy resin at each end. The shorter length is designed for retro-fitting to non-PCI systems.

To ensure system integrity, on-line permeate sampling from individual modules is available. Manufactured with materials approved by the FDA, CFR21 and EU regulations.



The open channel design processes liquids with high levels of suspended solids without plugging and facilitates highly effective cleaning in place.

The compact design gives the module a high strength allowing operating pressures of 7 bar. PCI's unique in-situ replaceable core enables fast, easy and cost effective remembraning.

"ULTRAFILTRATION (UF) IS A VARIETY OF MEMBRANE FILTRATION IN WHICH HYDROSTATIC PRESSURE FORCES A LIQUID AGAINST A SEMIPERMEABLE MEMBRANE. SUSPENDED SOLIDS AND SOLUTES OF HIGH MOLECULAR WEIGHT ARE RETAINED, WHILE WATER AND LOW MOLECULAR WEIGHT SOLUTES PASS THROUGH THE MEMBRANE. THIS SEPARATION PROCESS IS USED IN INDUSTRY AND RESEARCH FOR PURIFYING AND CONCENTRATING MACROMOLECULAR SOLUTIONS, ESPECIALLY PROTEIN SOLUTIONS. ULTRAFILTRATION IS APPLIED IN CROSS-FLOW AND SEPARATION IN ULTRAFILTRATION UNDERGOES CONCENTRATION POLARIZATION."

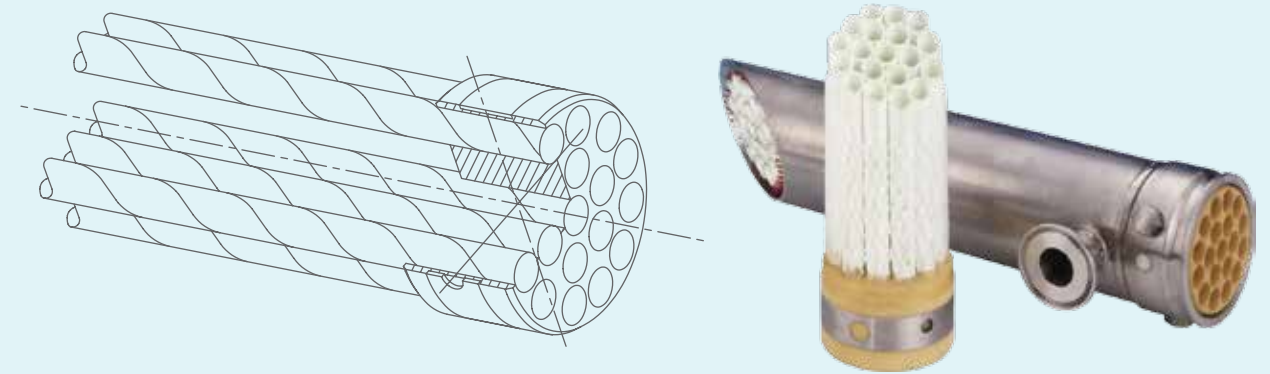

- REPLACEABLE MEMBRANE CORE
Allows fast, cost-effective remembraning, reducing downtime
- PROVEN MEMBRANES
With applications in the food, beverage, chemical, MBR and pharmaceutical industries
- COMPACT MODULE DESIGN
Quick and easy plant construction
- TUBULAR MODULE
Minimal prefiltration required, suited to viscous liquids and high levels of suspended solids

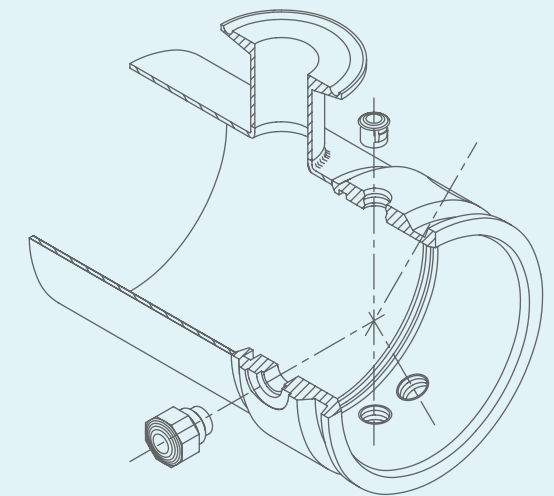

Dimensions		
Length (m)	3.05	3.66
Membrane Area (m ²)	2.18	2.62

Connections	
Permeate	1" tri-clamp or 3/4" 90° Spigot in AISI 316SS
Feed	3" tri-clamp in AISI 316SS

Additional Details	
Operating Pressure	Up to 7 bar max
Operating Temperature	Up to 60°C
Shroud Material	AISI 316 Stainless Steel
Membrane Type	A range of UF membranes in PVDF
pH Range	1.5-10.5

CASE STUDY HISTORY

- Page 54-55
Multi-stage Treatment of Landfill Leachate

The image shows a large industrial facility with several tall, cylindrical stainless steel tanks in the background. In the foreground, there is a complex system of stainless steel pipes and a large, multi-stage filtration unit. This unit consists of several parallel horizontal pipes, each with a series of curved, spiral-shaped components attached to its exterior. To the right of the filtration unit is a control cabinet with a digital display and various buttons. The floor is wet and reflective, and the ceiling has a grid of structural beams.

A37 SERIES

FILTRATION PROCESSING

BEVERAGE PROCESSING
APPLICATIONS

BIOMASS SEPARATION /
CONCENTRATION

WASTEWATER / EFFLUENT

SEPARATIONS / CONCENTRATION
(WITHIN MBR)

A37 SERIES

ULTRAFILTRATION MODULES

The A37 tubular UF system incorporates a robust, low-cost module in stainless steel or plastic, together with a choice of tubular membranes in various materials. The removable core design (RCM) permits simple, rapid, and inexpensive membrane replacement.

The modules are 3.66m in length, housing 37 membranes, 12.5mm in diameter, cast in epoxy resin at each end. The shorter length is designed for retro-fitting to non-PCI systems.

To ensure system integrity, permeate sampling from individual modules is available. Manufactured with materials approved by the FDA, CFR21 and EU regulations.



The open channel design processes liquids with high levels of suspended solids without plugging and facilitates highly effective cleaning in place.

The compact design gives the module a high strength allowing operating pressures of 7 bar. PCI's unique in-situ replaceable core enables fast, easy and cost effective remembraning.

"ULTRAFILTRATION (UF) IS A VARIETY OF MEMBRANE FILTRATION IN WHICH HYDROSTATIC PRESSURE FORCES A LIQUID AGAINST A SEMIPERMEABLE MEMBRANE. SUSPENDED SOLIDS AND SOLUTES OF HIGH MOLECULAR WEIGHT ARE RETAINED, WHILE WATER AND LOW MOLECULAR WEIGHT SOLUTES PASS THROUGH THE MEMBRANE. THIS SEPARATION PROCESS IS USED IN INDUSTRY AND RESEARCH FOR PURIFYING AND CONCENTRATING MACROMOLECULAR SOLUTIONS, ESPECIALLY PROTEIN SOLUTIONS. ULTRAFILTRATION IS APPLIED IN CROSS-FLOW AND SEPARATION IN ULTRAFILTRATION UNDERGOES CONCENTRATION POLARIZATION."

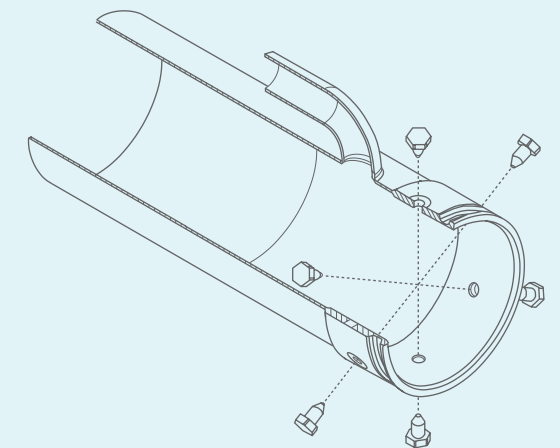
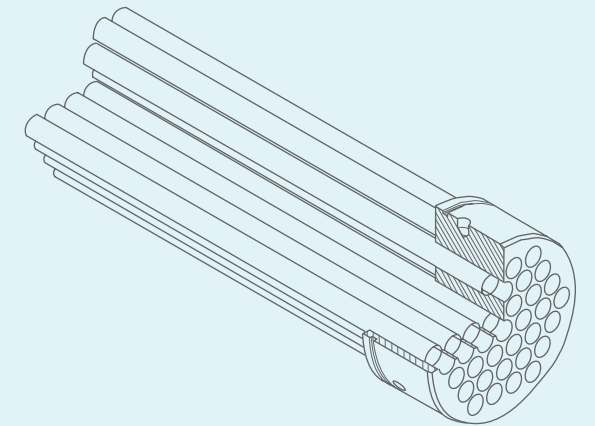
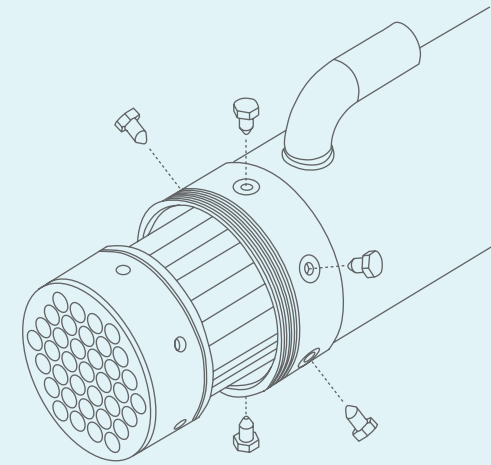

- **REPLACEABLE MEMBRANE CORE**
Allows fast, cost-effective remembraning, reducing downtime
- **PROVEN MEMBRANES**
With applications in the food, beverage, chemical, MBR and pharmaceutical industries
- **COMPACT MODULE DESIGN**
Quick and easy plant construction
- **TUBULAR MODULE**
Minimal prefiltration required, suited to viscous liquids and high levels of suspended solids

Dimensions	
Length (m)	3.66
Membrane Area (m ²)	5.10

Connections	
Permeate	1" tri-clamp or plain 90° Spigot in AISI 316SS
Feed	4" tri-clamp in AISI 316SS

Additional Details	
Operating Pressure	Up to 7 bar max
Operating Temperature	Up to 60°C
Shroud Material	AISI 316 Stainless Steel
Membrane Type	A range of UF membranes in PVDF
pH Range	1.5-10.5

CASE STUDY HISTORY

- **Page 52-53**
Ultra-compact wastewater plant for 'Venice's garden' (S'ant Erasmo)



B1 SERIES

HEALTHCARE, FOOD PROCESSING,
BEVERAGE, SPECIAL INDUSTRIAL &
FILTRATION PROCESSING

FINE CHEMICALS / DYESTUFFS
PHARMACEUTICAL / WASTEWATER

LANDFILL LEACHATE /
PULP EFFLUENT /
FRUIT JUICES DAIRY

B1 SERIES

UF, NF & RO MODULES

The tubular B1 module provides the user with a robust, proven, ultra filtration, nanofiltration and reverse osmosis module and a wide range of fully interchangeable membrane elements.

Each module, up to 3.6m long, comprises 18 perforated stainless steel tubes in the form of a shell and tube, each tube fitted with a membrane element. The shell, or shroud, is also fabricated from stainless steel and has outlets fitted for the permeate, the liquid that passes through the membrane.

Flow of the process fluid through the tubes is effected by specially designed end-caps whose design varies depending on the process requirements – *Series Flow, Twin Entry Flow, Parallel Flow.*



To ensure system integrity, permeate sampling from individual modules is available. Manufactured with materials approved by the FDA, CFR21 and EU regulations.

SERIES FLOW ARRANGEMENT
FOR REVERSE OSMOSIS SYSTEMS THE "SERIES FLOW" MODULE HAS CHANNELS MOULDED IN THE END-CAPS CONNECTING ALL THE 18 TUBES IN SERIES.

TWIN ENTRY FLOW ARRANGEMENT
AN END-CAP TYPE (KNOWN AS "TWIN" OR "DOUBLE-ENTRY") THAT PROVIDES TWO PARALLEL CHANNELS EACH OF NINE TUBES IN SERIES. ALLOWING VISCOUS MATERIALS TO BE PROCESSED AND HIGHER CROSSFLOW VELOCITIES TO BE USED WITH OVERALL PRESSURE DROP MINIMISED.

PARALLEL FLOW ARRANGEMENT
THIS END-CAP ALLOWS ALL 18 TUBES TO OPERATE IN PARALLEL ALLOWING THE HIGHEST CROSSFLOW VELOCITIES TO BE USED WITH ACCEPTABLE PRESSURE DROP.

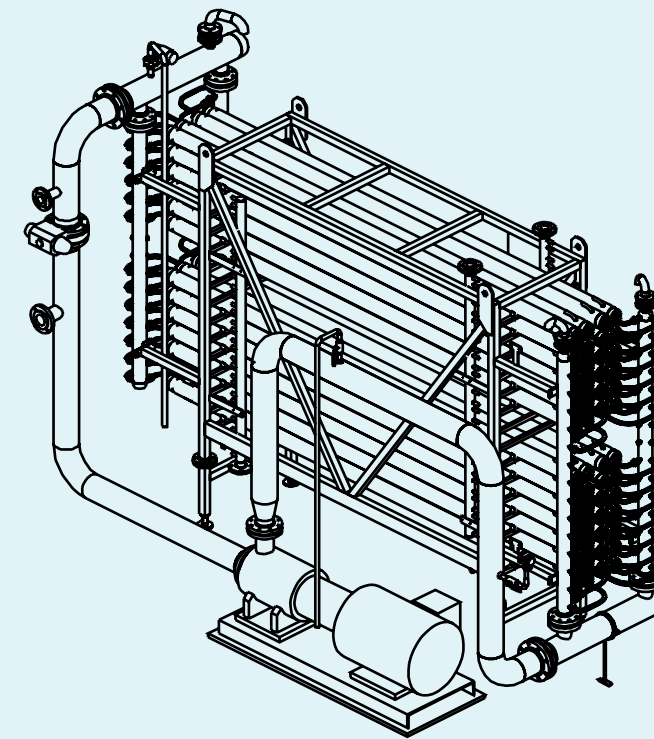

- **STAINLESS STEEL CONSTRUCTION**
Robust and inert to most chemicals
- **PROVEN MEMBRANES**
With applications in the food, beverage, chemical, industrial and pharmaceutical industries
- **COMPACT MODULE DESIGN**
Quick and easy plant construction
- **OPEN CHANNEL, TUBULAR DESIGN**
Minimal feed prefiltration required; suitable for high levels of suspended solids: Maximum effectiveness of CIP
- **CHOICE OF FLOW PATH THROUGH MODULE**
Optimum cross-flow velocities to minimise fouling with acceptable pressure drop.

Dimensions			
Length (m)	1.22	2.44	3.66
Membrane Area (m ²)	0.88	1.75	2.63

Connections	
Permeate	End Cap dependent (see following pages)
Feed	End Cap dependent (see following pages)

Additional Details	
Operating Pressure	Up to 64 bar (End Cap dependent)
Operating Temperature	Up to 80°C
Shroud Material	AISI 316 Stainless Steel
Membrane Type	Suitable for UF, NF & RO Membranes

CASE STUDY HISTORY

- [Page 54-55](#)
Multi-stage Treatment of Landfill Leachate
- [Page 58-59](#)
Tomato Juice Concentration
- [Page 60-62](#)
Tubular membrane effluent treatment plant

B1 SERIES

UF, NF & RO MODULES SERIES FLOW (RO) ARRANGEMENT

Each Reverse Osmosis module comprises 18 perforated stainless steel tubes in the form of a shell and tube, each tube fitted with a membrane element. Flow of the process fluid through each of the tubes is effected by specially designed end caps connecting all eighteen tubes in series. For viscous materials an alternative end cap arrangement is available which allows the overall pressure drop to be minimised.

The open channel, highly turbulent flow design allows a wide variety of process liquors to be concentrated, with minimal pretreatment. High levels of suspended materials can be tolerated. The design is free of dead spaces, which reduces the fouling potential of the membranes while ensuring maximum effectiveness of cleaning in-situ procedures.

SERIES FLOW ARRANGEMENT FOR REVERSE OSMOSIS SYSTEMS
THE "SERIES FLOW" MODULE HAS CHANNELS MOULDED IN THE END-CAPS CONNECTING ALL THE 18 TUBES IN SERIES.

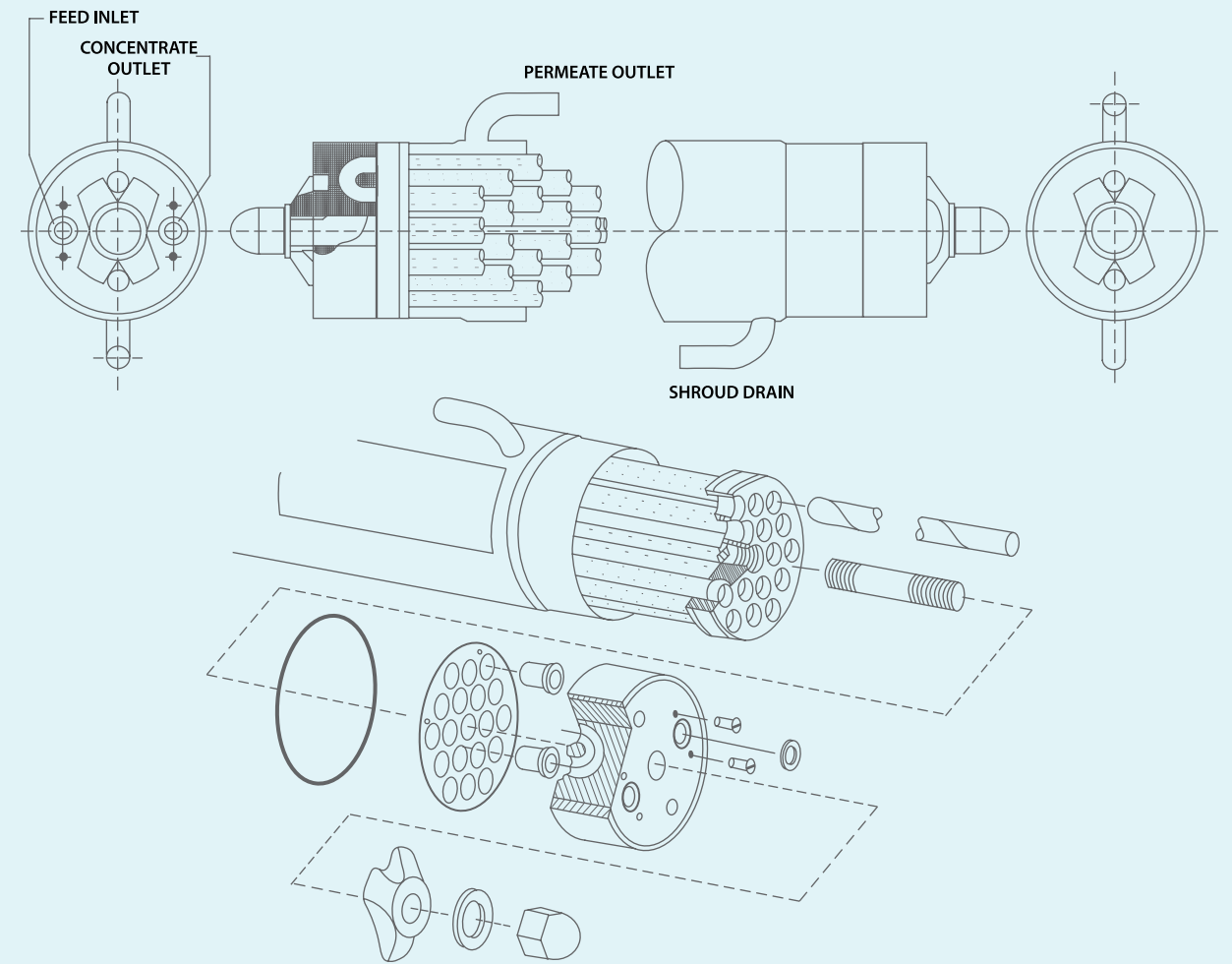
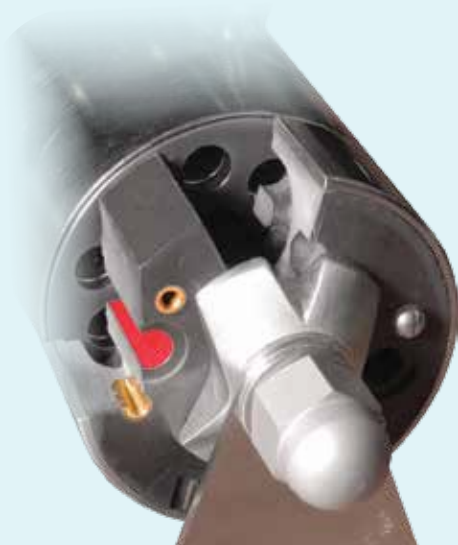

Module Length (m)	Membrane Area (m)	Weight Empty (kg)	Hold-up Volume Tube-side (Litres)	Hold-up Volume Shroud-side (Litres)	Membrane Tube ID. (mm)
1.22	0.88	14.4	2.8	6.7	12.5
2.44	1.75	24.0	5.6	13.3	12.5
3.66	2.63	33.7	8.4	20	12.5

Connections	
Permeate	12.5mm OD for flexible hose
Feed	For 12.5mm oval flange

Tube-Side Mechanical Operating Limits	
Operating Pressure	Up to 64 bar max
Pressure Drop	10 bar max
Operating Temperature	Up to 80°C
Shroud Material	AISI 316 Stainless Steel
Membrane Type	A range of NF & RO membranes

CASE STUDY HISTORY

- [Page 54-55](#)
Multi-stage Treatment of Landfill Leachate
- [Page 58-59](#)
Tomato Juice Concentration
- [Page 60-62](#)
Tubular membrane effluent treatment plant

B1 SERIES

ULTRAFILTRATION MODULES TWIN ENTRY ARRANGEMENT

Each ultrafiltration module comprises 18 perforated stainless steel tubes in the form of a shell and tube, each tube fitted with a membrane element. Flow of the process fluid through each of the tubes is effected by specially designed end caps providing 2 parallel channels, each of 9 tubes in series. This allows viscous materials to be processed and high cross flow velocities to be used with acceptable pressure drop.

For non-viscous materials with operation at high pressure (RO conditions) an alternative end cap arrangement is available which results in lower energy consumption.

The open channel, highly turbulent flow design allows a wide variety of process liquors to be concentrated, with minimal pretreatment. High levels of suspended materials can be tolerated. The design is free of dead spaces, which reduces the fouling potential of the membranes while ensuring maximum effectiveness of clean-in-situ procedures.

TWIN ENTRY FLOW ARRANGEMENT
AN END-CAP TYPE (KNOWN AS “TWIN” OR “DOUBLE-ENTRY”) THAT PROVIDES TWO PARALLEL CHANNELS EACH OF NINE TUBES IN SERIES. ALLOWING VISCOUS MATERIALS TO BE PROCESSED AND HIGHER CROSSFLOW VELOCITIES TO BE USED WITH OVERALL PRESSURE DROP MINIMISED.

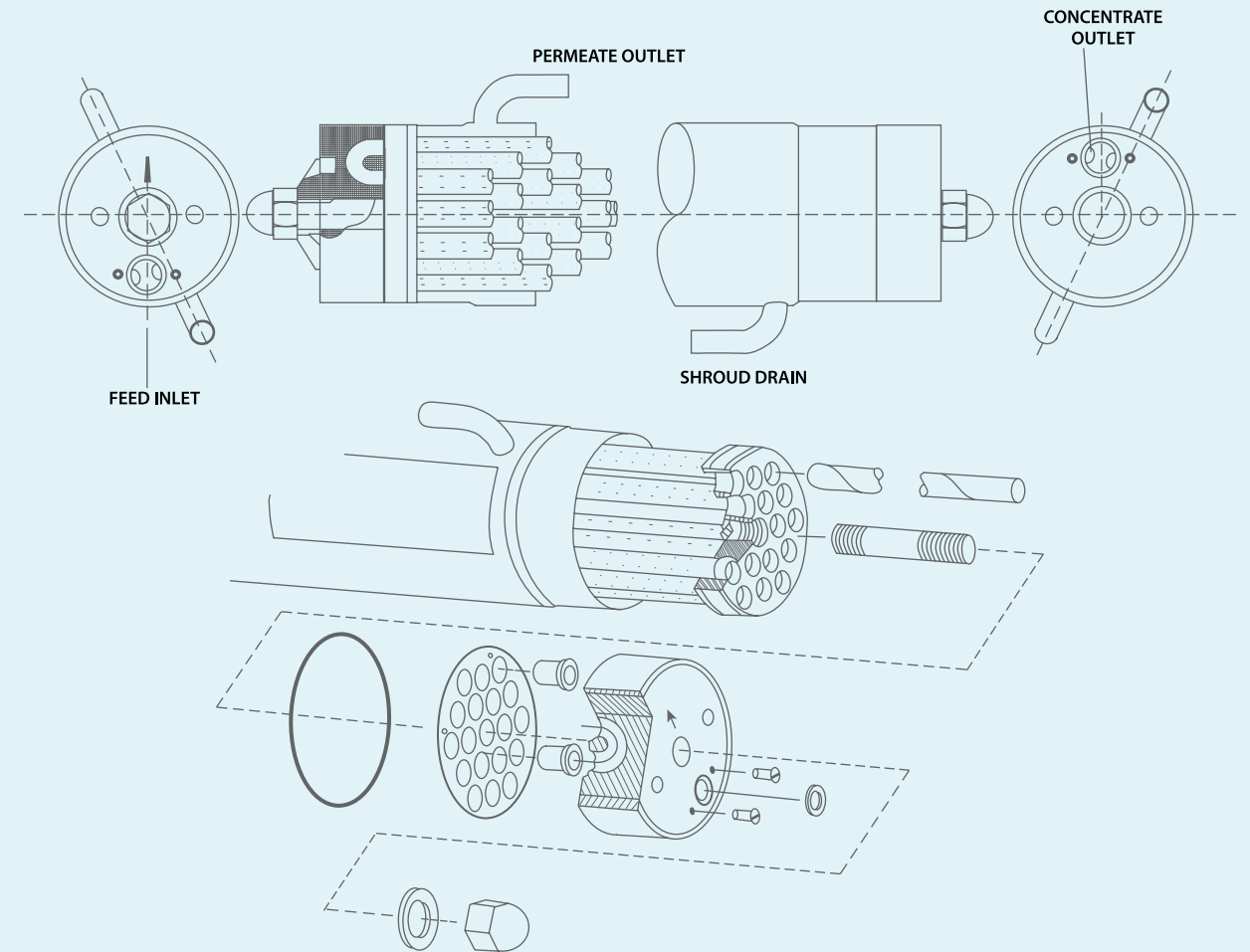

Module Length (m)	Membrane Area (m ²)	Weight Empty (kg)	Hold-up Volume Tube-side (Litres)	Hold-up Volume Shroud-side (Litres)	Membrane Tube ID. (mm)
2.44	1.75	24.0	5.6	13.3	12.5
3.66	2.63	33.7	8.4	20	12.5

Connections	
Permeate	19mm OD for flexible hose
Feed	For 19mm oval flange

Tube-Side Mechanical Operating Limits	
Operating Pressure	Up to 16 bar max
Pressure Drop	10 bar max
Operating Temperature	Up to 80°C
Shroud Material	AISI 316 Stainless Steel
Membrane Type	A range of UF membranes

CASE STUDY HISTORY

- [Page 54-55](#)
Multi-stage Treatment of Landfill Leachate
- [Page 58-59](#)
Tomato Juice Concentration
- [Page 60-62](#)
Tubular membrane effluent treatment plant

B1 SERIES

ULTRAFILTRATION MODULES PARALLEL FLOW ARRANGEMENT

Each module comprises 18 perforated stainless steel tubes in the form of a shell and tube, each tube fitted with a membrane element. Flow of the process fluid through each of the tubes is effected by specially designed end cap providing 18 parallel channels.

This allows viscous materials to be processed and high cross flow velocities to be used with acceptable pressure drop. For less viscous materials an alternative end cap arrangements are available which results in lower energy consumption.

The open channel, highly turbulent flow design allows a wide variety of process liquors to be concentrated, with minimal pretreatment. High levels of suspended materials can be tolerated. The design is free of dead spaces, which reduces the fouling potential of the membranes while ensuring maximum effectiveness of cleaning-in-situ procedures.

PARALLEL FLOW ARRANGEMENT
THIS END-CAP ALLOWS ALL 18 TUBES TO OPERATE IN PARALLEL ALLOWING THE HIGHEST CROSSFLOW VELOCITIES TO BE USED WITH ACCEPTABLE PRESSURE DROP.

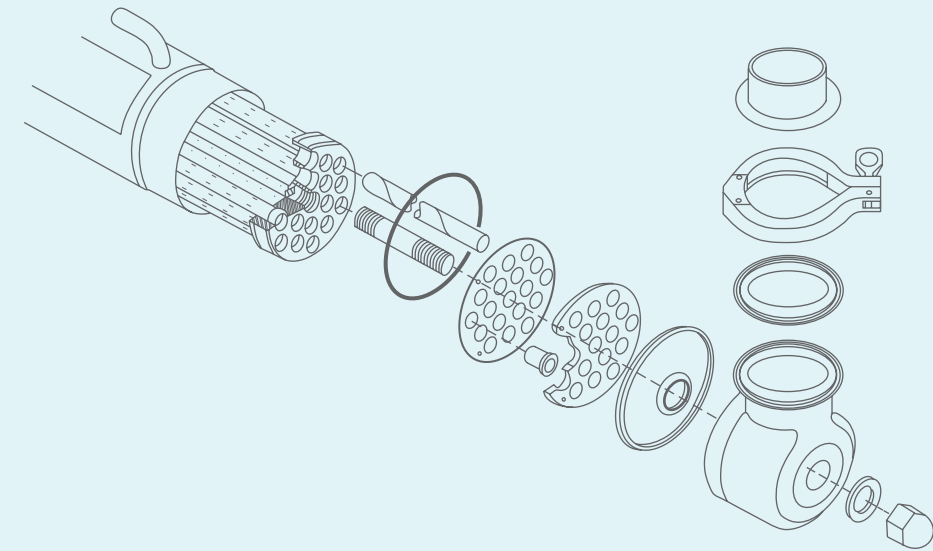
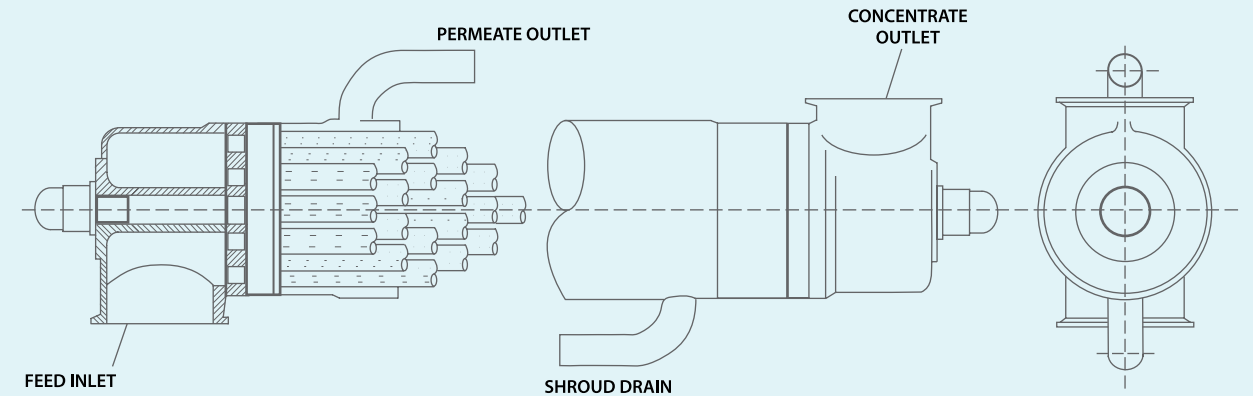

Module Length (m)	Membrane Area (m ²)	Weight Empty (kg)	Hold-up Volume Tube-side (Litres)	Hold-up Volume Shroud-side (Litres)	Membrane Tube ID. (mm)
2.44	1.75	24.2	6.4	13.3	12.5
3.66	2.63	33.8	9.2	20	12.5

Connections	
Permeate	19mm OD for flexible hose
Feed	For 2½" Tri-Clamp

Tube-Side Mechanical Operating Limits	
Operating Pressure	Up to 16 bar max
Pressure Drop	10 bar max
Operating Temperature	Up to 80°C
Shroud Material	AISI 316 Stainless Steel
Membrane Type	A range of UF membranes

CASE STUDY HISTORY

- [Page 54-55](#)
Multi-stage Treatment of Landfill Leachate
- [Page 58-59](#)
Tomato Juice Concentration
- [Page 60-62](#)
Tubular membrane effluent treatment plant



C10 SERIES

SPECIAL INDUSTRIAL
FILTRATION PROCESSING
MUNICIPAL WATER PROCESS

C10 SERIES

ULTRAFILTRATION & NANOFILTRATION MODULES

The C10 module, offers the user an economic tubular module which can be fitted with a wide range of proven nanofiltration and ultrafiltration membranes.

The module, has been developed to improve the competitiveness of tubular membrane plants, especially at larger capacities. It can be operated at 12 bar at 20°C.

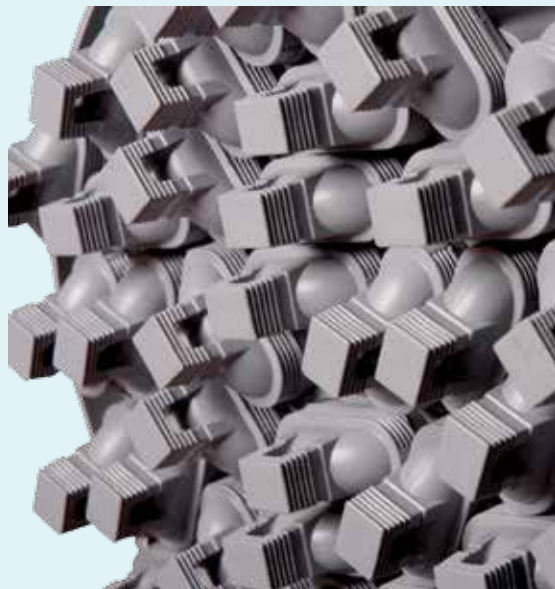

Membrane cleaning can be done mechanically with the use of foam balls and chemically using established clean-in-place techniques at extended frequencies, typically 4 times a year.

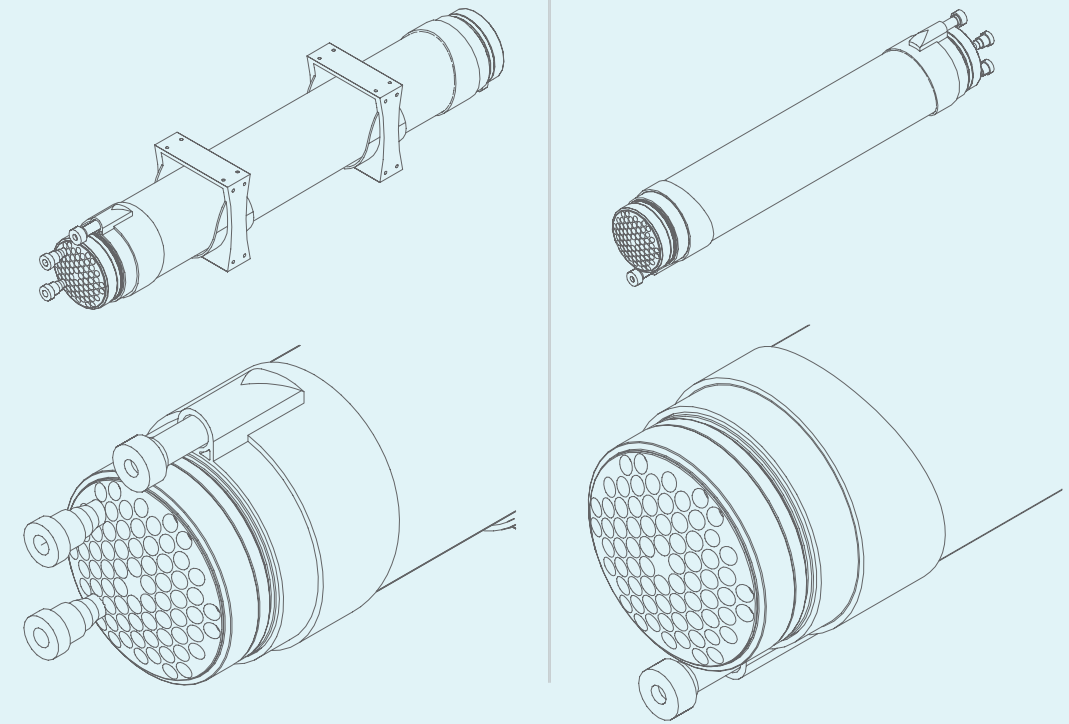

- SIMPLE MANIFOLD CONNECTIONS
Easy plant maintenance, reduced remembrating time
- ABS CONSTRUCTION
Lightweight, robust
- MODULAR DESIGN
Quick and easy plant construction
- TUBULAR MODULE
No prefiltration required



Dimensions			
Length (m)	3.66	1.83	0.92
Membrane Area (m ²)	10.5	5.2	2.6

Connections	
Permeate & Feed	End Cap dependent (see following pages)

Additional Details	
Operating Pressure	Up to 12 bar max
Operating Temperature	Up to 30°C
Shroud Material	ABS
Membrane Type	A range of UF and NF membranes
pH Range	Membrane specific

CASE STUDY HISTORY

- [Page 68-69](#)
The Fyne Process
- [Page 70-71](#)
Solution for rural water supplies with difficult sources (Achnasheen)
- [Page 72-74](#)
Solution for rural water supplies with difficult sources (Out Skerries)



**MICRO 240
& 960 SERIES**
SHORT-TERM EVALUATION
OF MEMBRANE PROCESSES
SEPARATION AND
CONCENTRATION AT LABORATORY

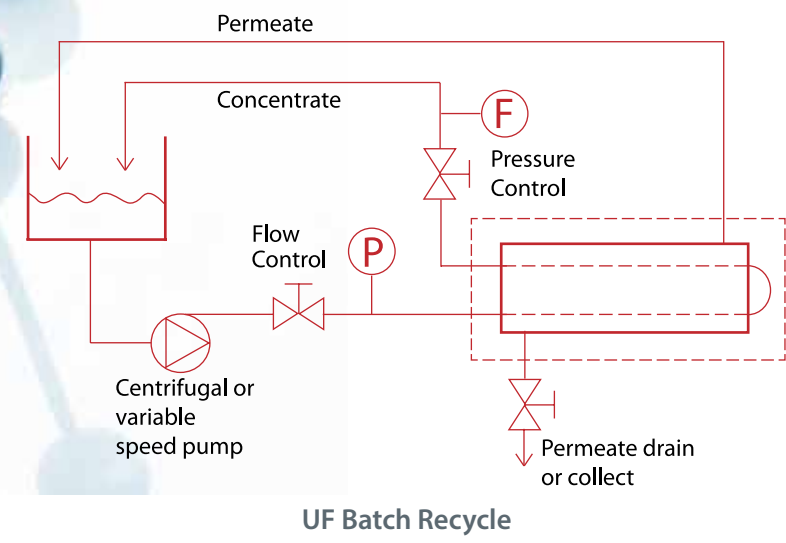
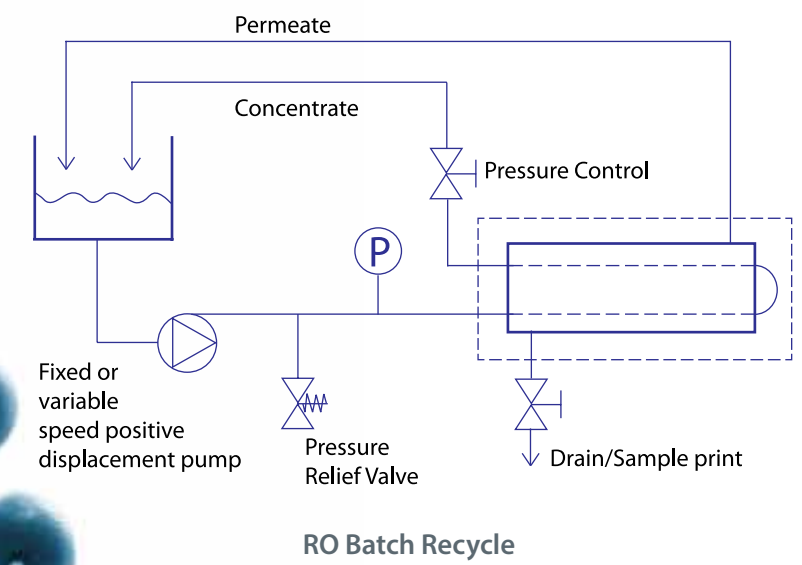

MICRO 240 & 960

SHORT-TERM RO, NF & UF EVALUATION MODULES

The MICRO 240 & 960 is designed for the economic, short term evaluation of membrane processes for separation and concentration at laboratory bench-scale.

This inexpensive module may be fitted, by the user, with samples of any of PCI Membranes' wide range of tubular Reverse Osmosis, Nanofiltration or Ultrafiltration membranes.



Constructed in 316 stainless steel, the module has termination points allowing easy connection by flexible or welded couplings to existing equipment.

Larger modules and ancillary components are available if required.

“REVERSE OSMOSIS (RO) IS A MEMBRANE SEPARATION METHOD THAT REMOVES MANY TYPES OF LARGE MOLECULES AND IONS FROM SOLUTIONS BY APPLYING PRESSURE TO THE SOLUTION WHEN IT IS ON ONE SIDE OF A SELECTIVE MEMBRANE. THE RESULT IS THAT THE SOLUTE IS RETAINED ON THE PRESSURIZED SIDE OF THE MEMBRANE AND THE PURE SOLVENT IS ALLOWED TO PASS TO THE OTHER SIDE. TO BE “SELECTIVE,” THIS MEMBRANE SHOULD NOT ALLOW LARGE MOLECULES OR IONS THROUGH THE PORES (HOLES), BUT SHOULD ALLOW SMALLER COMPONENTS OF THE SOLUTION (SUCH AS THE SOLVENT) TO PASS FREELY.”

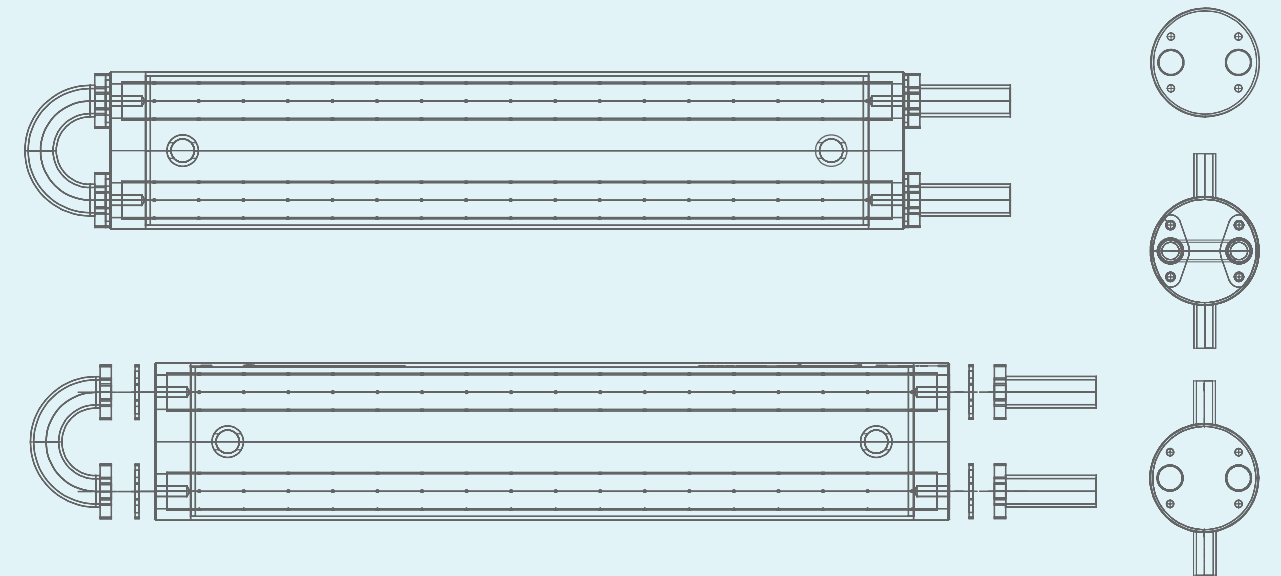

- **PROVEN MEMBRANES**
With applications in the food, beverage, chemical, MBR and pharmaceutical industries
- **COMPACT MODULE DESIGN**
Quick and easy laboratory setup
- **TUBULAR MODULE**
Minimal prefiltration required, suited to viscous liquids and high levels of suspended solids

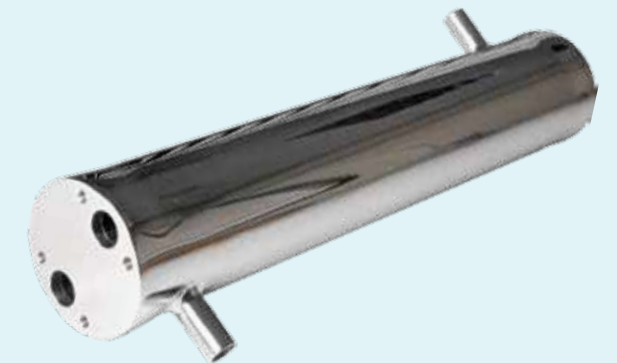

Dimensions		
	Micro 240	Micro 960
Length (m)	2 off 1.25cm dia x 30cm tubes connected in series	2 off 1.25cm dia x 1.2m tubes connected in series
Membrane Area (m ²)	240 cm ² (0.024m ²)	960 cm ² (0.096m ²)

Connections	
Permeate Flow	5-50 ml/min
Recommended Pressure	40 Bar for RO; 4 Bar for UF
Recommended Recycle Flowrate	18 l/min for RO, equivalent to 2.5m/s; 30 l/min for UF, equivalent to 4m/s;
Pressure Drop (Water) at 2m/s	0.15bar (2 psi)
Pressure Drop (Water) at 4m/s	0.5bar (7 psi)

Additional Details		
	Micro 240	Micro 960
Operating Pressure	55 Bar at 70°C; 70 Bar at 20°C max	55 Bar at 70°C; 70 Bar at 20°C max
Tubeside volume	75ml	228ml
Permeate volume (full)	750ml (Approx)	912ml (Approx)
Permeate volume (empty)	50ml (Approx)	200ml (Approx)
Construction	316 Stainless Steel with Nitrile rubber seals. (Other seal materials available)	316 Stainless Steel with Nitrile rubber seals. (Other seal materials available)

A5 MINI MODULE

LOW COST MODULE FOR
TESTING AND EVALUATION
OF THE A5 MEMBRANE

FOR APPLICATIONS CONTAINING
SUSPENDED SOLIDS



A5 MINI MODULE

ULTRAFILTRATION TEST MODULES

The Mini-module is a low cost module for testing and evaluating A5 membranes which are ideally used for applications containing suspended solids. Specifically designed to be compatible with the PCI BRO pilot plant, it is also suitable for fitting to a range of other test units.

This enables the client to test the suitability of one of the standard A5 membranes or an experimental membrane in the laboratory or pilot hall, before going to the expense of full-scale modules.

Each 1.2m long module is fitted with five membrane tubes each of 6mm diameter, yielding a membrane area of 0.1m². The module shell is constructed in ABS or PVC and the membrane tubes are bonded into the shell with epoxy resin.



All types of commercial A5 membranes are available, and where appropriate, development membranes can be supplied.

Modules may be used individually, or be connected in series or parallel, subject to the flows and pressures available from the test rig to which they are fitted.

“ULTRAFILTRATION (UF) IS A VARIETY OF MEMBRANE FILTRATION IN WHICH HYDROSTATIC PRESSURE FORCES A LIQUID AGAINST A SEMIPERMEABLE MEMBRANE. SUSPENDED SOLIDS AND SOLUTES OF HIGH MOLECULAR WEIGHT ARE RETAINED, WHILE WATER AND LOW MOLECULAR WEIGHT SOLUTES PASS THROUGH THE MEMBRANE. THIS SEPARATION PROCESS IS USED IN INDUSTRY AND RESEARCH FOR PURIFYING AND CONCENTRATING MACROMOLECULAR SOLUTIONS, ESPECIALLY PROTEIN SOLUTIONS. ULTRAFILTRATION IS APPLIED IN CROSS-FLOW AND SEPARATION IN ULTRAFILTRATION UNDERGOES CONCENTRATION POLARIZATION.”

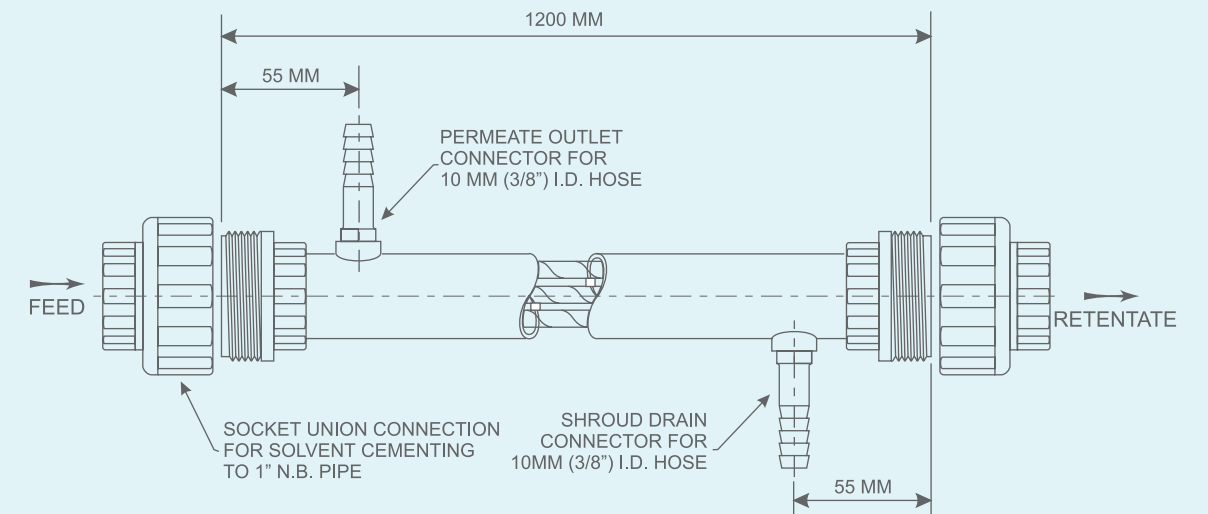

- **PROVEN MEMBRANES**
With applications in the food, beverage, chemical, MBR and pharmaceutical industries
- **COMPACT MODULE DESIGN**
Quick and easy laboratory setup
- **TUBULAR MODULE**
Minimal prefiltration required, suited to viscous liquids and high levels of suspended solids

Dimensions	
Length (m)	1.2m
Membrane Area (m ²)	0.1m ²
Flow Area	5 tubes at 6mm diameter

Connections	
Fittings	1" socket union for inlet/outlet 10mm (3/8") hose tail for permeate outlets

Additional Details	
Operating Pressure	Up to 10 bar max
Operating Temperature	Up to 60°C
Typical Flow Rates	20-30 l/min
Shroud Material	ABS or PVC
Membrane Type	A range of UF membranes in PVDF
pH Range	1.5-10.5



PILOT UNITS

FOR PILOT SCALE PRODUCTION
AND MEMBRANE PROCESSING

PILOT UNITS

PILOT SCALE PRODUCTION AND PROCESSING

Pump, Pipe Work

The feed pump is a stainless steel triplex plunger type, usually variable speed, producing a maximum operating pressure of 80 bar. Most pipe-work in contact with feed fluid is of 316 stainless steel construction. Various pipework options are available, including recycle for high recoveries and additional pressure, temperature and flow indicators.

Heat Exchanger

A heat exchanger is fitted to maintain the temperature of the recycled liquor at the desired value. The shell and tube design is of similar construction to the B1 module, 0.6m in length and constructed of AISI 316 stainless steel.

The Membranes and Modules

The unit can be fitted with:

- 1 x 1.2m long B1 tubular module of 0.9m² membrane area (all applications).
- Single 2.5" spiral elements and housing.
- Single tube tester for membrane selection. Unit has 6 x 1.2m long single tubes fitted in series.

Cleaning

All membranes are easy to clean by simple clean in place procedures at low pressures. An optional cleaning tank can be supplied.

We can recommend the most suitable membrane and module type for your application. We can also provide test programmes, and from the data collected design full-scale plants and supply budget or firm quotations.

"PILOT UNIT DESCRIPTION

THE UNIT IS DESIGNED FOR PILOT SCALE WORK AND MAY BE USED TO PROCESS A WIDE VARIETY OF AQUEOUS SOLUTIONS USING REVERSE OSMOSIS (RO), NANOFILTRATION (NF) OR ULTRAFILTRATION (UF). A WIDE RANGE OF MEMBRANES IS AVAILABLE TO SUIT THE REQUIRED APPLICATION.

BOTH DESIGNS ARE SUPPLIED WITH INSTRUMENTATION NECESSARY FOR SCALE UP DATA TO BE COLLECTED ACCURATELY AND EASILY. CUSTOMISATION IS AVAILABLE TO ALLOW USE FOR SMALL PRODUCTION REQUIREMENTS IN CONTINUOUS, SEMI CONTINUOUS OR BATCH OPERATION."

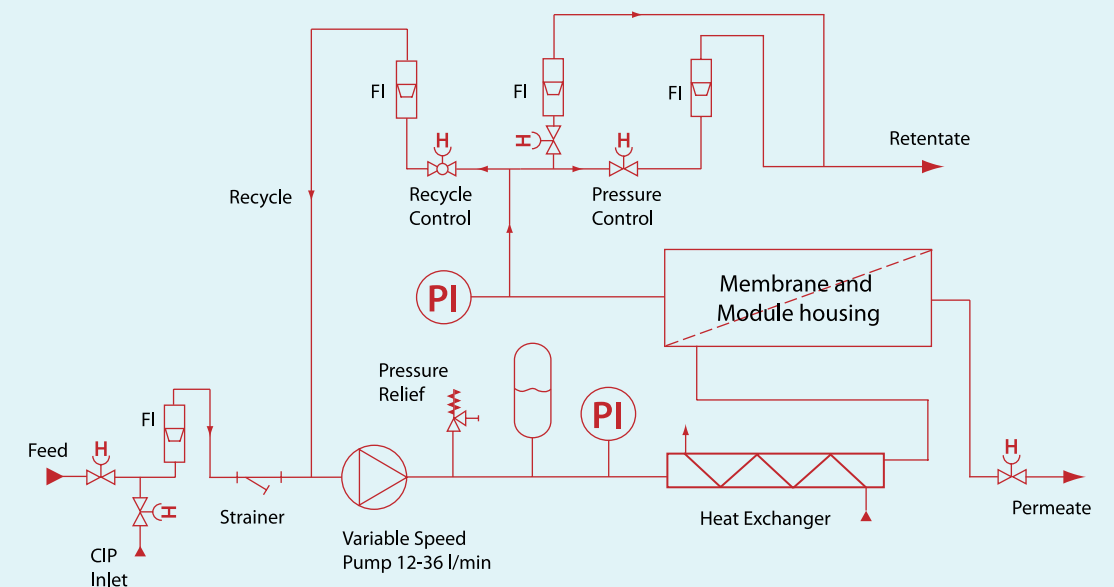

- **PROVEN MEMBRANES**
With applications in the food, beverage, chemical, MBR and pharmaceutical industries
- **COMPACT MODULE DESIGN**
Quick and easy laboratory setup
- **TUBULAR MODULE**
Minimal prefiltration required, suited to viscous liquids and high levels of suspended solids

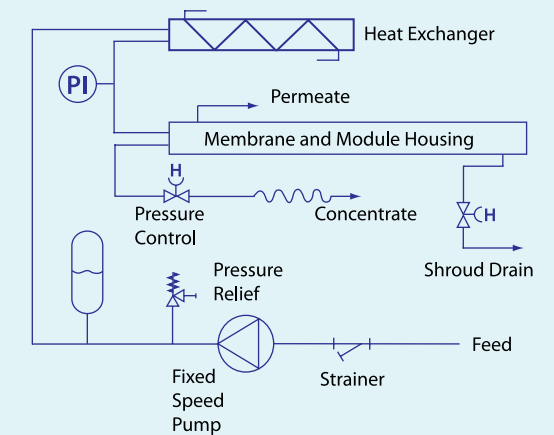

Dimensions	
Length (m)	2m (approx)
Height (m)	1.5m
Width (m)	0.8m when fitted with 1.2m B1 module
Membrane Area (m ²)	Depending on membrane and module type

Connections	
Power Requirements	4.0/5.5 kW (fixed/variable speed) 380 or 415 V/3 ph & earth, 50 Hz
Weight	150kg approximately when fitted with 1.2m B1 module

Additional Details	
Operating Pressure	Up to 64 bar depending on membrane type fitted
Operating Temperature	1-80°C depending on membrane type fitted
Membrane Type	A range of RO, UF or NF membranes
pH Range	1-14 (to suit membrane type fitted)

CASE STUDY HISTORY

- **Page 60-62**
Tubular membrane effluent treatment plant

TUBULAR MEMBRANES

SUITED TO FLUIDS WITH
HIGH VISCOSITY AND/OR
SUSPENDED SOLIDS



TUBULAR MEMBRANES

PILOT SCALE PRODUCTION AND PROCESSING

Tubular membranes are particularly suited to fluids with high viscosity and/or suspended solids, as their wide flow paths make them highly resistant to blocking. Pre-treatment requirements are minimal, and are often completely avoided – a benefit that makes membranes the most cost effective choice for many small systems.

Membrane Development

Our development chemists continuously refine product performance to expand our range, extending the benefits to users to offer. Our in-house development and manufacturing capability enables us to provide customised membranes tailored for specific applications. This can prove highly beneficial where short process development times are the key. New developments include hydrophilic membranes for lower fouling, improved selectivity, increased solvent, acid and base resistance, improved flux and strengthened membrane supports.

Proprietary Tubular Membranes

All membranes are produced “in-house” in our purpose-built facility, operating under the international Quality Assurance standard ISO 9001:2015. The table (opposite) provides a technical summary of our range of modules which are fully compatible with our tubular membranes.

Cleaning

The choice of cleaning chemicals and cleaning frequency depend upon the nature of the process and the membrane type. Acids, Alkalis and Detergents are used as required. Typical cleaning procedures are indicated on the below table. The C10 type applications can also be cleaned mechanically using an automated “pigging” process that uses foam balls and can significantly reduce the need for cleaning chemicals.

Membrane Type	Chemical	Concentration	Temp °C
AFC99	Alkaline Detergent Nitric acid	0.25% 0.3%	50 50
AFC80,40,30	Enzyme Nitric acid	0.5% 0.3%	45 45
CA/AN	Enzyme Nitric Acid	0.5% pH2.0	30 30
ES/PU/FP FPN (Excluding FPA/FPT/LPA/ LMA)	Chlorinated Alkaline detergent Nitric acid	1% 0.3%	45 45

CLEANING AGENTS

Type	Application	Length	Diameter	Membrane Area	Standard Options/Comments
A5	UF	3.1m 3.7m	83mm 83mm	4.0m ² 4.75m ²	Shroud AISI 316 stainless steel.
A19	UF	3.1m 3.7m	83mm 83mm	2.1m ² 2.5m ²	Shroud AISI 316 stainless steel.
A37	UF	3.7m	119mm	5.2m ²	Shroud AISI 316 stainless steel
B1 Parallel Flow	UF	1.2m 2.4m 3.7m	100mm 100mm 100mm	0.9m ² 1.7m ² 2.6m ²	For highly viscous materials, and low pressure drop.
B1 Twin-Entry	UF	1.2m 2.4m 3.7m	100mm 100mm 100mm	0.9m ² 1.7m ² 2.6m ²	End-caps in epoxy or AISI 316 stainless steel. Shroud AISI 316 stainless steel.
B1 Series Flow	RO, NF, UF	1.2m 2.4m 3.7m	100mm 100mm 100mm	0.9m ² 1.7m ² 2.6m ²	End-caps in epoxy or AISI 316 stainless steel. Shroud AISI 316 stainless steel.
C10	NF, UF	0.9m 1.8m 3.7m	210mm 210mm 210mm	2.5m ² 5.0m ² 10.5m ²	DWI approved ABS wetted parts.
Micro 240	RO, NF, UF	0.3m	63.5mm	0.024m ²	AISI 316 stainless steel module (2 membrane tubes). Membrane micropacks available.
Micro 960	RO, NF, UF	1.2m	63.5mm	0.096m ²	AISI 316 stainless steel module (2 membrane tubes). Membrane micropacks available.
Single Tube	RO, NF, UF	1.2m	12.5mm	0.283m ²	For comparing up to 6 membrane types

TECHNICAL SUMMARY OF OUR MODULE RANGE

Membrane Type	Material	pH Range	Operating Pressure	Operating Temperature	Nominal Retention Character ¹	Generic Specification	Hydrophilicity ²	Solvent Resistance ³	Applicable Module/s
AFC99	Polyamide Film	1.5-12	64 ⁴	80 °C	99% NaCl	RO	3	++	B1
AFC80	Polyamide Film	1.5-10.5	60	70 °C	80% NaCl	RO	4	++	B1
AFC40	Polyamide Film	1.5-9.5	60	60 °C	60% CaCl ₂	NF	4	++	B1
AFC30	Polyamide Film	1.5-9.5	60	60 °C	75% CaCl ₂	NF	4	++	B1 / C10
CA202	Cellulose Acetate	2-7.25	25	30 °C	2,000 MW	UF	5	+	B1 / C10
ESP04	Modified PES	1-14	30	65 °C	4,000 MW	UF	2	++	B1
ES404	Polyethersulphone	1.5-12	30	80 °C	4,000 MW	UF	2	++	B1 / C10
EM006	Modified PES	1.5-12	30	80 °C	6,000 MW	UF	4	++	B1
PU608	Polysulphone	1.5-12	30	80 °C	8,000 MW	UF	2	++	B1
ES209	Polyethersulphone	1.5-12	30	80 °C	9,000 MW	UF	2	++	B1
PU120	Polysulphone	1.5-12	15	80 °C	20,000 MW	UF	2	++	B1
FPT03	PVDF	1.5-10.5	10	60 °C	20,000 MW	UF	1	+++	A5
FPA03	PVDF	1.5-10.5	7	60 °C	20,000 MW	UF	1	+++	A19 / A37
AN620	Polyacrylonitrile	2-10	10	60 °C	25,000 MW	UF	5	+++	B1
ES625	Polyethersulphone	1.5-12	15	80 °C	25,000 MW	UF	2	++	B1
FPT10	PVDF	1.5-10.5	10	60 °C	100,000 MW	UF	1	+++	A5
FPA10	PVDF	1.5-10.5	7	60 °C	100,000 MW	UF	1	+++	A19 / A37
FP100	PVDF	1.5-12	10	80 °C	100,000 MW	UF	1	+++	B1
FPT20	PVDF	1.5-10.5	10	60 °C	200,000 MW	UF	1	+++	A5
FPA20	PVDF	1.5-10.5	7	60 °C	200,000 MW	UF	1	+++	A19 / A37
FP200	PVDF	1.5-12	10	80 °C	200,000 MW	UF	1	+++	B1
FPN200 ⁶	PVDF	1.5-12	10	65 °C	200,000 MW	UF	1	+++	B1
LPA450	PVDF	1.5-10.5	7	60 °C	450,000 MW	UF	1	+++	A19 / A37
LMA02	PVDF	1.5-10.5	7	60 °C	0.2µm	MF	1	+++	A19 / A37

TECHNICAL SUMMARY OF OUR RANGE OF PROPRIETARY TUBULAR MEMBRANES.

Notes:

¹ Retention character depends on several parameters, including nature of the test solution. This information should therefore be used as a guide only.

² 1 Low, 5 high

³ + Low, +++ high

⁴ Available with sodium metabisulphite or proxel preservative

⁵ Maximum pressure limited by module.

⁶ Polypropylene substrate

TUBULAR MEMBRANES

FILTRATION SOLUTIONS

Applications

Applications where tubular membranes have been selected as the best process solution include:

- Wood pulp bleach wastewater separation
- Lignosulphonate fractionation
- Side-stream (external) membrane bioreactors (MBRs)
- Landfill leachate treatment
- Metal finishing wastewater separation
- Active Pharmaceutical Ingredient manufacture
- Manufacture of fine chemicals (various)
- Dairy applications (e.g. milk concentration)
- Fruit juice clarification
- Drinking water treatment
- Textile dye processing (e.g. desalting)
- Textile process wastewater treatment/reuse
- Clean In Place (CIP) solution recovery
- Product recovery
- Acid purification
- Process R & D (academic and industrial)

Our range of over 22 tubular membranes incorporates products that are suitable for all these applications. The variety of materials employed provides a range of chemical compatibilities, with their exhaustive development delivering unmatched performance. The range also incorporates products with UK Drinking Water Inspectorate approval, proving their suitability for municipal applications.

PCI MEMBRANES SUPPLIES ITS PRODUCTS AS COMPONENTS TO OEM SYSTEMS BUILDERS, DIRECTLY TO END USERS (EITHER AS COMPONENTS OR AS COMPLETE MEMBRANE SOLUTIONS), AND AS SPARES FOR OUR OWN AND OTHERS' TUBULAR MEMBRANE SYSTEMS.

QUALITY ASSURANCE – PROVEN MEMBRANES

PCI Membranes designs, manufactures and provides supply and servicing of equipment for liquid separation to the quality standard: BS EN ISO 9001:2015

Destructive testing is carried out on samples of every membrane batch, as well as 100% performance testing of all RO and NF membranes. Finished membranes are preserved and stored under carefully-controlled conditions to prevent deterioration during storage. A computerised records and bar-coding system provides for complete traceability of each membrane produced, and facilitates traceability to confirm that the membranes meet PCI Membranes high quality standards.

PCI Membrane products are offered with guarantees commensurate with their application and conditions of use. Additionally our experience of delivering membrane solutions allows us to provide extensive process performance guarantees when offering complete systems.

Case studies and References





Panoramic view of Venice, Italy.
Home to CP Srl.

Case studies and References *A SERIES*



WASTEWATER TREATMENT

CASE STUDY – ULTRA-COMPACT WASTEWATER PLANT FOR ‘VENICE’S GARDEN’ A37 SERIES MODULES AND MEMBRANES

Case Study: Sant’Erasmus, Venice, Italy

High-throughput filtration membranes are at the heart of an extremely compact wastewater treatment plant on Sant’Erasmus island in the Venice lagoon. Engineered by CP Srl, the sidestream bioreactor configuration employed is one of around 100 in the Venice area alone employing advanced filtering technology from PCI Membranes.

Background

Venice’s wastewater treatment network is highly distributed, with many small processing plants handling groups of houses or buildings, or single large installations such as hotels. The plant on Sant’Erasmus is on an even larger scale. It processes all of the wastewater treatment for the population of the mainly agricultural island – which produces fruit and vegetables for the city’s population – as well as wastewater from the densely-populated island of Burano.

For this application, which handles up to 1000 cubic metres a day or the equivalent wastewater output of around 4000 people, CP chose to use PCI Membranes’ largest stainless steel tubular system, the A37 module. Housing 37 tubular polymeric membranes within a 100 mm diameter, 3.66 m

long stainless steel housing, each A37 module provides a cross-flow filtration surface area of five square metres. As the membranes will operate with a pressure of up to seven bar (102 PSI), multiple modules can be connected in series and driven by pumps to achieve high throughputs.

Design Criteria	
System	Pumped with 2 parallel processing lines
Treatment	1000m ³ per day
Modules	90 modules (2 x 45)
Filtration Area	450m ²
Footprint	Less than 5 x 5m, with a height of only 2.8m



System

The system for Sant’Erasmus is a membrane bioreactor – a wastewater treatment system combining biological oxidation with activated sludge and a filtration system. An underground basin handles the sedimentation, de-nitrification and nitrification treatment stages, while the pressurised sidestream filtering system separates the solid and liquid phases. The particular filtration configuration designed for this application is a pumped system with two parallel processing lines constructed using 45 tubular A37 modules each, providing some 450 square metres of filtration area in total. These two processing lines are assembled with U-bend components to form compact processing stacks. The approach allows the complete filtration system to sit on a footprint of less than 5 x 5 m, with a height of only 2.8 m.

In operation, biomass flows into an activated sludge biological treatment basin or bioreactor for break-down of the organic material. It is cycled through the ultrafiltration plant to remove the sludge and high molecular weight solids. These solids are sent back to the bioreactor until they can no longer be degraded, and are periodically removed for a final de-watering phase and then disposal. Separated particle-free effluent is ozone polished before being re-used for irrigation.

History

CP has been using PCI Membranes for almost 20 years, and has configured and installed over 1000 filtration systems for projects ranging from processing landfill leachate to municipal and industrial wastewater treatment. Partly as a result of its extensive work in the Venice region, the company has developed numerous system building techniques and configurations to provide processing plants that are very compact and which can be shaped to fit into available spaces, but which remain maintainable. CP also employs

special processing techniques which reduce the energy consumption of sidestream membrane bioreactor configurations by up to 50-60%.

“Sidestream membrane systems are much easier to access and maintain than submersed filtration systems, and are also ideal for sensitive environments such as Venice because there is no need for lifting equipment, which in this case would have increased building height”, comments Darren Reed of PCI Membranes. “These attributes, and the system engineering by CP, mean that the Sant’Erasmus installation fits into a single-storey building, allowing the plant to blend unobtrusively into the flat farming landscape.”

The CP engineer who worked on the St. Erasmus plant, Silvano Levorin, adds: “Sidestream membrane systems are particularly advantageous for many of the wastewater treatment plant projects we handle, which are in sensitive and conservation areas. We particularly like using PCI Membranes filtration because of the ease with which its tubular-mounted modules can be built into systems and maintained. Almost every system we build is also unique in some way, and PCI Membranes always works with us to provide the components we need for the optimum solution.”



WASTEWATER TREATMENT

CASE STUDY – MULTI-STAGE TREATMENT OF LANDFILL LEACHATE. B1 AND A19 MODULES WITH AFC99 AND FPA20 MEMBRANES

Case Study: Damsdorf Landfill, Germany

Background

At Damsdorf in Germany, the existing 15 hectare landfill site, which had no bottom sealing or leachate collection system was approaching capacity. A new site was constructed in 2 sections, each of 6 hectares, with a total refuse capacity of 3 million cubic metres. This new site had bottom and top-sealing systems, and a leachate treatment system incorporating biological pretreatment using ultrafiltration and reverse osmosis for leachate concentration.

Filling and Leachate Collection

In order to minimise the time taken to achieve methanogenesis when the site was new, a special filling leachate collection method was used. Each of the main sections of the landfill were subdivided into a number of compartments. The first compartment was layered with compacted and loose refuse comprising materials from the old site mixed with new. This reduced the time taken to achieve methanogenesis from the normal 2 years to about 9 months.

When compartment 1 was full, the other compartments were used. Leachate from all compartments is taken through compartment 1 (which is in the methanogenic phase) before collection. This ensured that the quality of the leachate changed only gradually after the first year of operation.

“REVERSE OSMOSIS (RO) IS A MEMBRANE FILTRATION METHOD THAT REMOVES MANY TYPES OF LARGE MOLECULES AND IONS FROM SOLUTIONS BY APPLYING PRESSURE TO THE SOLUTION WHEN IT IS ON ONE SIDE OF A SELECTIVE MEMBRANE. THE RESULT IS THAT THE SOLUTE IS RETAINED ON THE PRESSURISED SIDE OF THE MEMBRANE AND THE PURE SOLVENT IS ALLOWED TO PASS TO THE OTHER SIDE. TO BE “SELECTIVE,” THIS MEMBRANE SHOULD NOT ALLOW LARGE MOLECULES OR IONS THROUGH THE PORES (HOLES), BUT SHOULD ALLOW SMALLER COMPONENTS OF THE SOLUTION (SUCH AS THE SOLVENT) TO PASS FREELY.”

Biological Pretreatment/ Ultrafiltration

Biological pretreatment uses the Activated Sludge Process, which comprises prefiltration, denitrification in a 125m³ stirred tank, and two 125m³ aeration tanks. The tubular ultrafiltration (UF) system recovers the biomass post-nitrification. A 10-fold concentration of biomass is achieved, and the concentrated biomass is recycled to the de-nitrification stage. Approximately 3% of the UF permeate (biologically-pretreated leachate) is recycled to the aeration tanks for foam control.

Reverse Osmosis

The UF permeate is concentrated by 2-stage RO. The first stage uses PCI’s tubular membrane system, and achieves a concentration factor of up to 5. The permeate from the first stage is then concentrated in the second stage, which uses PCI’s spirally-wound membrane system and achieves a concentration factor of 4. Both stages operate at 40-50 bar as well as ambient temperature, and are chemically cleaned on a weekly basis. The cleaning solution is returned to the biological pretreatment process. The concentrate from the second stage is returned to the first stage.

Evaporation

The installation comprises a 2-effect evaporator which achieves a 10-fold concentration.

Raw Leachate Quality

- Leachate volume – average (m³/d) 80
- COD (mg/l) 5,000
- BOD (mg/l) 500
- Ammonia (mg/l) 1,500
- AOX (mg/l) 3.5
- Conductivity (mS/cm) 18



Design Criteria	
RO I	187m ² membrane area, 5m ³ /h feed
RO II	97.5m ² membrane area, 3.4m ³ /h feed
Evaporator	2-effect, 10m ³ /h
Drier	1.0m ³ /h

CROSSFLOW MEMBRANE TECHNOLOGY

- Reduces pollutants and contaminants
- Meets local water discharge legislation
- Increases efficiency & effectiveness of biological treatment systems
- Provides a cost effective means of treating leachate with minimum space requirements
- Treats a variety of leachate types
- Designed to meet specific site demands e.g. fluctuations in volumes and composition



Panoramic view of Piacenza, Italy.
Home to ARP Tomato Juice Concentration Site.

Case studies and References

B SERIES



TOMATO JUICE CONCENTRATION

CASE STUDY – CONCENTRATION OF TOMATO JUICE B1 SERIES MODULES AND AFC99 MEMBRANES

Case Study: ARP, near Piacenza, Italy

Background

ARP has expanded continuously since 1958 when 7000 tonnes of tomatoes were processed, up to 100,000 tonnes/year (1984 figures). The factory produces 28°-30° Brix and 36°-38° Brix concentrate for major European clients.

Previous Process

In the 1983 season the factory process was the standard hot break process with feed juice at an average of 4.5° Brix going to 2 large triple effect evaporators which concentrate 80 tonnes/hr of feed juice directly to concentrate/paste product. The water removal requirement for 28°-30° Brix product was about 67 tonnes/hr, with a steam consumption of about 25 tonnes/hr at an operating cost of £500/hr.

New Process

ARP decided to expand production by approximately 50% over a two year period. Two competitive offers for a third large triple effect evaporator were considered in conjunction with PCI's reverse osmosis system.

The traditional evaporator scheme would have required additional capital investment in steam boiler capacity, evaporator cooling system and the related civil engineering costs for these three major items. In addition to this, further increases in the already high fuel oil costs would make the evaporation step a major factor in the overall total processing costs for the factory.



1st Season

The first stage of the expansion was carried out by installing the 42 tonnes/hr three stage PCI reverse osmosis plant. The line pre-concentrated to 8.5° Brix, removing almost 20 tonnes of water per hour, with a total energy consumption of approximately 150kw of electrical power.

The existing evaporators carried out the final concentration to 28°-30° Brix or 36°-38° Brix. The initial expansion with the first reverse osmosis line increased overall plant capacity by 900 tonnes/day.

2nd Season

two additional lines were ordered for 1985 to give a total reverse osmosis plant capacity of 126 tonnes/hr. All tomato pulp juice is pre-concentrated to 8.5° Brix prior to the existing evaporators and the overall capacity of the factory was increased by nearly 50%.

The overall factory scheme is shown below:

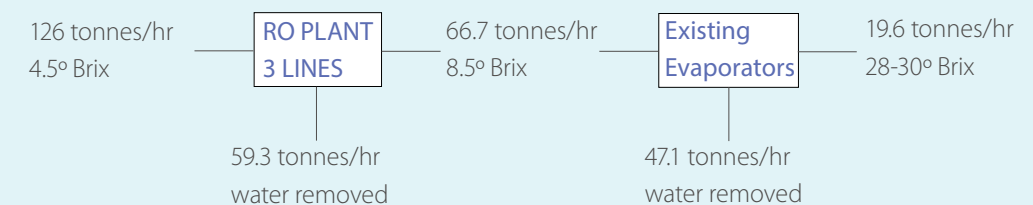

Operating Costs (1995 figures)		
Existing	3 Effect Evaporators	£3.30/tonne water removed (based on steam cost plus electricity)
PCI	Reverse Osmosis plant	£1.70/tonne water removed (based on steam cost plus electricity)
Saving	Removing 59.3 tonnes/hr of water by RO for 21 hr/day – £1,922 a day	

CONCLUSION

- Increase processing capacity by up to 50%
- Reduce operating costs by £1,992/day (1995 figures)
- Avoid costly investments in a new evaporator plus the associated new steam, boiler, cooling water system and services

The Situation Today

ARP's production has expanded to 150,000 tonnes of process tomatoes a year. New products have been added to their range such as cubed chopped tomatoes and concentrated tomato juice known as 'Passata'.

The number of active farmers around Piacenza forming part of the co-operative has reduced slightly. However, they have embraced the new technologies allowing them to produce higher quality products with cost-effective production methods.

EFFLUENT TREATMENT PLANT

CASE STUDY – THE WORLD’S LARGEST TUBULAR MEMBRANE EFFLUENT TREATMENT PLANT B1 SERIES MODULES AND ES404 (SOFTWOOD) & EM006 (HARDWOOD) MEMBRANES

Case Study: Stora Nymölla AB, Sweden

Introduction

Stora Nymölla AB is one of the world’s largest manufacturers of bleached magnifite pulp. Production of pulp started in 1962 at Nymölla, and actual paper manufacture began in 1972. At present, the mill’s capacity is 300,000 tonnes per year, of which 200,000 tonnes is used by Stora Nymölla for the manufacture of high quality printing paper. The remaining pulp is sold to other paper mills. Two types of pulp are produced, Nymölla Red, which is a short fibre pulp made from beech and birch, and Nymölla Green, a long fibre pulp made from pine and spruce.

From the oxygen bleach stage of the pulping process, 300 tonnes per hour of effluent is produced (made up of 135 tonnes per hour from hardwoods and 165 tonnes per hour from softwoods). The average COD of this effluent is approximately 10gm/litre, therefore a total of about 3 tonnes of COD is produced every hour. Due to stricter legislation, and the need to be “green”, it became necessary for Stora Nymölla to obtain the “Swan” mark for their products.

This is an independently awarded symbol indicating commitment to protecting the environment. The mill was already chlorine-free, but they needed to reduce COD emissions to achieve the “Swan” mark. The target was a 50% reduction in the total mass of COD discharged from the oxygen bleach stage. The retained 50% of the COD was to be contained in 2% of the original liquid volume so that it could be incinerated.



Production Plant	
System	13 recirculation stages (7 for softwood and 6 for hardwood).
Process	300m ³ /hr of effluent and producing 6m ³ /hr of concentrate
Modules	1784 B1 Modules in total Softwood stage contains 1064 modules Hardwood stage contains 720 modules.
Filtration Area	4650m ²

Trials

Stora Nymölla approached MoDo Chemetics who came to PCI Membranes, where we were invited to carry out trials. These were started in May 1993 using a multi-stage recycle pilot plant. The initial results indicated that Nymölla’s bleach effluent was treatable with membranes, but that further work was required.

In October 1993, PCI returned to site with an ultrafiltration (UF) pilot plant. This was a two-stage plant fitted with three modules per stage, giving a total of 15.6m² membrane area. The plant could be operated in batch or continuous mode and at a stable concentration or VCF (volumetric concentration factor) within each stage.

The trials in May indicated the need for a 4,000 Dalton cut-off membrane, and so PCI’s ES404 polyethersulphone membrane was fitted in the pilot plant. The two streams of effluent (hardwood and softwood) needed to be treated separately in order that the retentate stream could be reused.

One target was to design a plant that could operate at low cross-flow velocities in order to keep energy consumption down. This proved to be possible for the softwood stream, and a total of about three months of continuous trials, operating 24 hours per day, were carried out on the softwood effluent using ES404 membranes.



View of feed end of softwood stages.
Note: Small diameter pipework – a feature of operating at low cross-flow rates.

During this time a number of different cleaning regimes were tested, and it was determined that a variable cleaning frequency was needed. Earlier stages were found to require more frequent cleaning, approximately once daily, and later stages could be run continuously for four days or more.

During the early part of the trials, hardwood effluent was also trialled using ES404 membranes. However, this stream proved to be far more fouling than the softwood effluent for these membranes even when a high crossflow was employed. Therefore a smaller pilot plant was then taken to site, and various other membranes were trialled for the hardwood using this plant, whilst the main pilot plant continued to produce data on the softwood effluent. It became clear that none of PCI’s existing membranes was suitable and so a new membrane had to be developed. This was achieved in less than two months, so trials with the two-stage UF pilot plant were able to continue uninterrupted.

The new membranes worked exactly as anticipated; it was also discovered that all hardwood stages of the projected full-scale plant should be able to be operated for two days between cleans.

Production Plant

Once MoDo Chemetics had secured the order from Nymölla, the production plant was designed and built jointly by MoDo Chemetics and PCI Membrane Systems. Installation and commissioning was also carried out jointly, with engineers from PCI spending time working together with MoDo engineers in Sweden.

The final design was for two lines with a total of thirteen recirculation stages (7 for softwood and 6 for hardwood). Each softwood stage contains 152 modules and each hardwood stage 120 modules. The lines are designed such that they never have to stop. Any stage can be taken off line to enable it to be cleaned without interrupting the effluent processing.

Conclusion

Since January, 1995, the plant has met the required specification for both COD reduction and capacity, processing more than 300m³/hr of effluent and producing 6m³/hr of concentrate. Membrane life has been longer than forecast, with both power and cleaning chemical consumption also within the guaranteed limits.

In all PCI:

- Carried out close to 1000 hours of trial work
- Developed a new membrane in only two months
- Tailored two different cleaning regimes to the two feed types
- Designed a plant that successfully processes 300m³/hr of bleach effluent.

The plant has enabled Stora Nymölla to achieve the sought-after "Swan" mark.



View of feed end of sixth stage of hardwood line.
Note: Larger diameter feed pipework



13 stages of PCI 3.6 m long B1 modules. A total membrane area of 4650m².
Note: Stages are staggered to make space for re-membraning.



View of valley in Wester Ross, Scotland.
Home to one of our Fyne Process Sites.

Case studies and References

C SERIES



THE FYNE PROCESS

CASE STUDY – SOLUTION FOR RURAL WATER SUPPLIES WITH DIFFICULT SOURCES C10 SERIES TUBULAR MEMBRANES

Case Study: Technical Development

Introduction

The Fyne process is a simple, single stage process that employs advanced membrane filtration technology, together with screening, post conditioning and disinfection, to treat poor quality, variable water sources for municipal drinking water supply.

The Fyne process has repeatedly been proven to provide the lowest capital, operating and hence whole life costs for small to medium sized systems, with installed plants having capacities ranging from 3m³/day to 1420m³/day; and is particularly suited to water sources containing carbonaceous organic colour and pathogens such as Cryptosporidium.

No Coagulants

Conventional treatment processes often remove fine particles (such as colour and pathogens) using chemical coagulants, which have various drawbacks, including:

- Health and safety concerns for operational staff and the environment
- Transportation issues and specialist on-site handling and storage requirements

- Production of chemical bearing sludge, requiring costly removal, re-processing and disposal
- Delayed response to changes in raw water quality, causing process performance implications.

The Fyne process does not require coagulants as the membranes operate at a molecular level, hence the process does not generate sludge and maintains a high quality of treatment water in spite of both sudden and substantial changes in raw water quality.



Tubular Membranes

PCI Membranes' own 12mm diameter tubular membranes are used in the Fyne process due to their ability to handle suspended solids without blocking. The nanofiltration (NF) membranes retain contaminants on the raw water side and allow potable water to permeate. The deposition of impurities upon the membrane's surface is minimised by maintaining a high crossflow velocity using a partial re-cycle flow, thereby sustaining high filtration efficiencies. As the process' waste stream is simply concentrated raw water, there are no environmental concerns to prevent local water course disposal.

Membrane Cleaning

The membranes are routinely cleaned using a mechanical pigging technique employing natural foam rubber balls (see page 28 for image).

After a predetermined operational time period the plant's flow direction is automatically reversed, causing the balls to be passed along the length of the membrane tubes, thus scouring accumulated deposits from the filtration surface. The removed deposits are disposed of via the waste stream to the local water course. This unique feature makes the Fyne Process more environmentally sensitive than all conventional treatment alternatives.



A C10 tubular membrane module

Package Membrane Plants

PCI Membranes has recently introduced Package Membrane Plants (PMPs) for the Fyne process, which offer the following features:

- Reduced costs and delivery times
- Performance testing prior to shipping – minimising on-site commissioning
- Single phase electrical supplies can be used as a power source for smaller sites – easing installation in remote locations
- Minimal footprint

As the PMPs are supplied as complete treatment processes incorporating all the necessary peripheral items, they simply require positioning within a building and connection to services before final performance validation is commenced. Full instrumentation can be incorporated to enable unattended monitoring and limited site attendance. Custom engineered plant are offered for larger capacities and/or specific customer requirements.

Applications

The Fyne process provides a filtration barrier to the following contaminants (amongst others):

- Organic carbon – the principal pre-cursor of disinfection by-products (e.g. carcinogenic THMs)
- Pathogens – including bacteria, protozoan cysts (e.g. Cryptosporidium) and viruses
- Metals – including iron, aluminium and manganese
- Turbidity, Suspended Solids and algae

References and Reliability

Since its development in 1992, over 70 Fyne process plants have been installed across the world, principally in Scotland, Canada and the USA. The process has been verified under the US Environmental Protection Agency's "Environmental Technology Verification" program, and approved by the UK's Drinking Water Inspectorate and approved by the Scottish Executive. The proven performance of the Fyne process over extended time periods has resulted in it being specified as a standard treatment solution by some customers and gives PCI Membranes confidence in offering robust performance guarantees.

ACHNASHEEN WATER TREATMENT WORKS

CASE STUDY – SOLUTION FOR RURAL WATER SUPPLIES WITH DIFFICULT SOURCES C10 SERIES TUBULAR MEMBRANES

Case Study: *Achnasheen Wester Ross, Scotland*

Introduction

Achnasheen is a village community of 120 people in Wester Ross, 40 miles North of Inverness in the Highlands of Scotland. Water from the Achnasheen burn has traditionally been filtered and chlorinated before being supplied to the village. The existing treatment process has consistently failed to meet Scottish Water's drinking water quality standards due to high colour passage, with the subsequent chlorination causing carcinogenic disinfection by-products to be generated in the form of tri-halo methanes.

Challenge

As with many Highland burn sources, the raw water at Achnasheen is both variable in quality and quantity, leading to peaks of colour and turbidity,

particularly when the burn is in spate. Being an elevated site, cold temperatures and snow melt were design considerations, with water temperatures of less than 1°C being common in winter months. An overview of the raw water quality and treatment required is tabulated below. Scottish Water's product water specification also included a requirement to remove micro organisms to safeguard against pathogens.



Parameter	Units	Raw Water	Product Water
Colour	°Hazen	156	5
Turbidity	FTU	3	0.4
pH		5.5-8.0	8.0-9.5
Aluminium	µg/l	168	50
Iron	µg/l	1030	50
Manganese	µg/l	164	20
TOC	mg/l	11	2

Design

PCI Membranes broke new ground at Achnasheen in January 2004 with the installation of the first ever Fyne Package Membrane Plant (PMP). Developed to minimise cost and program duration, the PMP was constructed in a transportable building at PCI's production facility, where it was commissioned prior to shipment. A diagram of the process is below.

Raw water is conveyed 500m from the burn source to the PMP by gravity, with surge protection incorporated to protect against plant damage. At the core of the process are seven 3.6m long C10 tubular membranes each of which contains 72 membranes. Each module has a membrane surface area of 10.5m², giving an overall plant membrane area of 73.5m². The plant operates at a nominal flux rate of 24 litres/m²/hr at 10°C and a recovery rate of 85%. The reduction in the permeability of water that occurs when its temperature drops is overcome by incorporating variable speed pump drives into the design, thereby ensuring the required capacity can be produced throughout the year. Residual chlorination and pH correction is provided before the treated water is pumped to 70m³ high level clear water storage tank, from where it is supplied into Achnasheen's distribution system.

Performance

Working in partnership with Scottish Water using a Value Based Product Development philosophy to establish the PMP concept, the approach ensured that the needs of the end users were fully addressed and the maximum benefit of PCI Membranes process expertise could be realised. The successful completion of the Achnasheen PMP contract within both time and budget is evidence of the effectiveness of this approach. The plant was constructed and commissioned in 24 weeks, with site installation and testing requiring a further 8 weeks. The project returned a saving of 30% in both cost and program duration compared to traditional design and construct style of contracts that preceded it.

Since going into production the plant has comfortably outperformed the required quality standards, providing very high quality drinking water to the residents. This is reflected in the comments PCI receives from Scottish Water's customer, with one resident having expressed the view, "it is reassuring to know that the residents of a small community such as ours are receiving water of a quality that is equal to or better than any in the entire country".

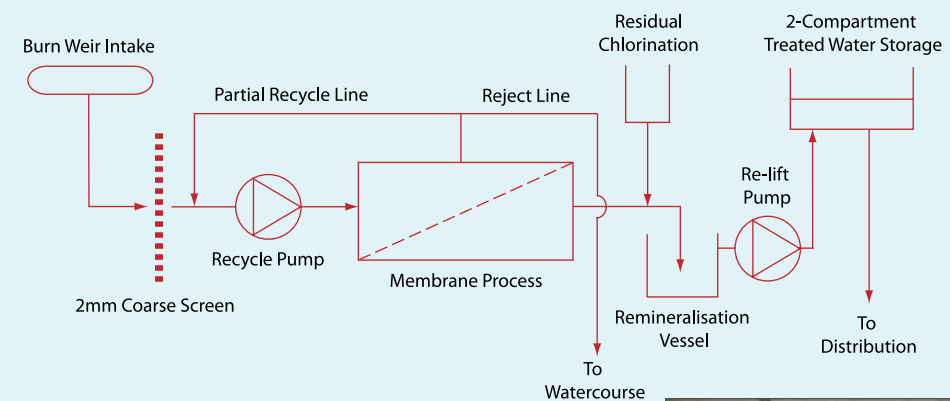

Production Plant	
System	Fyne Package Membrane Plant (PMP)
Process	Nominal flux rate of 24 litres/m ² /hr at 10°C and a recovery rate of 85%
Modules	Seven 3.6m long C10 tubular membranes each of which contains 72 membranes
Filtration Area	73.5m ²



Interior photo of the package membrane plant

OUT SKERRIES WATER SUPPLY PLANT

CASE STUDY – SOLUTION FOR RURAL WATER SUPPLIES WITH DIFFICULT SOURCES C10 SERIES TUBULAR MEMBRANES

Case Study: Out Skerries, Shetland Islands, Scotland

Introduction

Out Skerries is a group of three small islands with a population of approximately 100 inhabitants in the extreme most northerly tip of Scotland, 30 miles due north east of Shetland. This location presents issues of remoteness and requires consideration of the sensitive environmental context.

The islands, all connected by bridges, had an existing high level water treatment works employing media filtration, which regularly failed to produce water to potable standards due to high concentrations of colour leading to the creation of carcinogenic disinfection by products. The raw water source

was a rainwater runoff collection trough circling the main hill on the largest island, which supplied the works via an impounding storage reservoir and auxiliary steel tank. The treated water was then distributed via a network serving the three islands. In addition to poor water quality, the islands suffered from shortages of water volumes during extended dry periods.

Challenge

To overcome the shortcomings of the existing system, North of Scotland Water required improvements to be made in both drinking water quality and the available raw water quantity. The rainwater collection trough was recognised as being inadequate to provide the required security of supply, hence it was decided to drill ground water abstraction boreholes to augment this source.

Parameter	Units	Surface Water	Borehole 9	Borehole 11	Final Water
Colour	°Hazen	76.1	6	6	5
Turbidity	FTU	1.6	94	15	0.4
pH		6.9-7.8	7.4-7.9	7.2-7.3	8.0-9.5
Aluminium	µg/l	357	163	157	50
Iron	µg/l	332	251	342	50
Manganese	µg/l	18	202	92	20
TOC	mg/l	15	3.4	2.9	2
Chloride	mg/l	414	194	742	250
Sodium	mg/l	213	152	151	200

In total fourteen boreholes were drilled and subjected to hydrogeological testing, of which the two most suitable were selected (numbers 9 and 11). Most of the boreholes were found to have very poor water quality and/or insufficient yields and hence could not be used. The proximity of the sea caused all of the boreholes to exhibit relatively high salinity, as did the rainfall collection trough due to salt spray during windy weather. The runoff collection system caused organic pollutants in the soil to contaminate the raw water, which was further exacerbated by infiltration into the impounding reservoir. The raw water quality of the three sources, together with the product water quality specification, has been tabulated opposite.

It was decided that the borehole sources would be employed for 10 hours per day (subject to conductivity limits), with the surface water runoff collection system being used to top-up supplies and hence meet demand. The challenge was to provide an environmentally sensitive process solution capable of treating any of the three sources in whatever mix of raw water volumes was available, to continuously comply with the product water quality specification.

Contract Award

North of Scotland Water employed leading industry consultant Hyder Consulting to develop a tender and select appropriate organisations with suitable technologies for this challenging situation. PCI Membranes was awarded the contract as a result of the customer's and consultant's confidence in the technical solution and the lowest whole life costs offered. PCI Membranes' extensive track record in this field of water treatment and commitment to supporting the customer were also instrumental in the success.

Not only was the Fyne process' innovative foam ball cleaning system ideally suited to this pristine environmental context (enabling all wastes to be disposed of to the local environment), but also the wealth of membrane technology experience that exists in PCI Membranes enabled the technology to be optimally applied in these unique circumstances. In addition to the design, build, installation and commissioning of the Fyne water treatment process, the contract included equipping the boreholes with abstraction plant and head works.

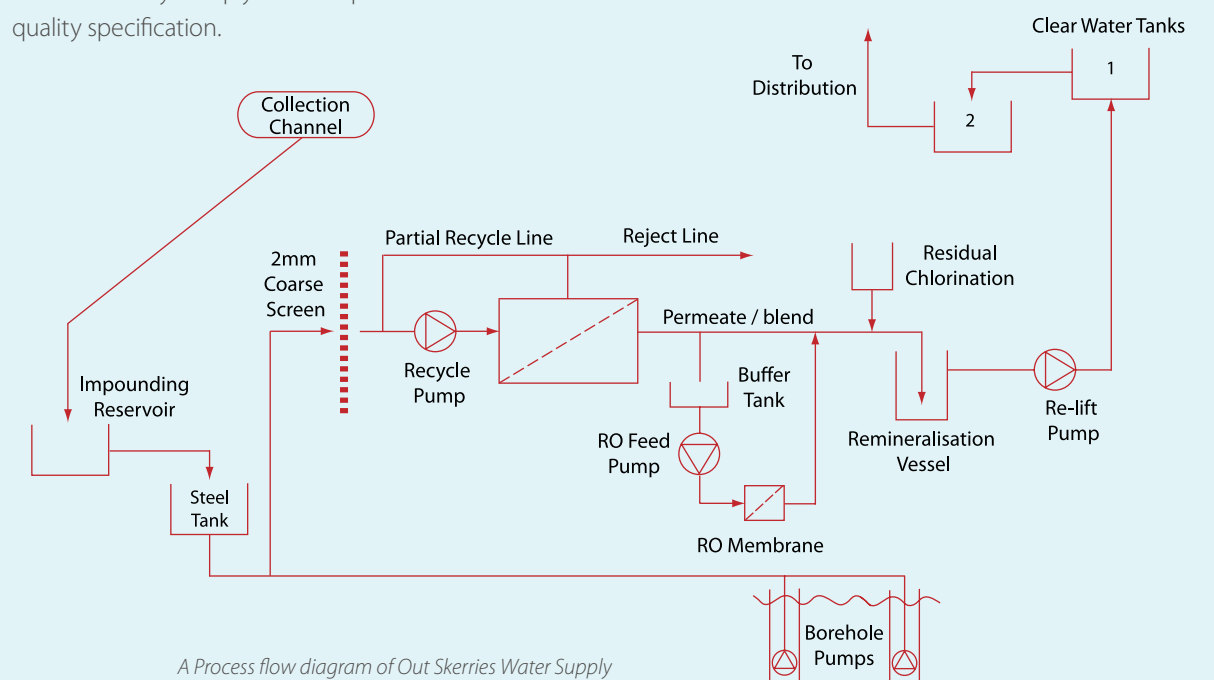

A Process flow diagram of Out Skerries Water Supply

Design

The treatment plant design comprised a primary nanofiltration tubular membrane process to remove colour and metals, followed by a secondary low pressure Reverse Osmosis (RO) spiral wound membrane polishing stage (treating 40% of the design flow rate) to reduce the concentration of dissolved salts. This combination ensures that the product water, which is a blend of the membrane

plants' permeates, complies with drinking water quality standards. It also minimises the need for cleaning chemicals to regain the filtration performance of the RO stage by reducing the contaminant load sent to it, and therefore its size. Following post treatment disinfection and conditioning, the flow is re-lifted to clear water storage tanks prior to distribution.

Production Plant	
System	Recycle tubular Fyne with partial final polish by Reverse Osmosis
Process	Surface Water Treatment with ingress from sea water
Modules	8 off 3.6m long C10 tubular membranes each of which contains 72 membranes
Capacity	30m ³ /day

