





# Isotop® MSN

## Steel spring isolators for low installation heights

- Natural frequency from 3.5Hz
- Low overall height of 57 mm
- Electro-galvanised or cathodic dip-coated (CDC) for increased corrosion protection
- Secure connection between the plate and the spring thanks to special adhesive
- M 8 internal thread
- Simple load control thanks to open design
- Spring design conforms to DIN EN 13906-1

		Maximum load		Natural frequency at maximum load	Packaging unit	Order number
		in kg	in N			
<b>MSN spring element galvanised</b> 	Isotop® MSN 1	3	29	3.5 Hz	50 pcs.	<b>39376</b>
	Isotop® MSN 2	5	49	3.5 Hz	50 pcs.	<b>39377</b>
	Isotop® MSN 3	9	88	3.5 Hz	50 pcs.	<b>39378</b>
	Isotop® MSN 4	14	137	3.5 Hz	50 pcs.	<b>39379</b>
	Isotop® MSN 5	23	226	3.5 Hz	50 pcs.	<b>39380</b>
	Isotop® MSN 6	35	343	3.5 Hz	50 pcs.	<b>39381</b>
	Isotop® MSN 7	53	519	3.5 Hz	50 pcs.	<b>39382</b>
	Isotop® MSN 8	90	883	3.5 Hz	50 pcs.	<b>39383</b>
<b>MSN spring element CDC</b> 	Isotop® MSN 1 CDC	3	29	3.5 Hz	100 pcs.	<b>39384</b>
	Isotop® MSN 2 CDC	5	49	3.5 Hz	100 pcs.	<b>39415</b>
	Isotop® MSN 3 CDC	9	88	3.5 Hz	50 pcs.	<b>39416</b>
	Isotop® MSN 4 CDC	14	137	3.5 Hz	50 pcs.	<b>39417</b>
	Isotop® MSN 5 CDC	23	226	3.5 Hz	50 pcs.	<b>39418</b>
	Isotop® MSN 6 CDC	35	343	3.5 Hz	50 pcs.	<b>39419</b>
	Isotop® MSN 7 CDC	53	519	3.5 Hz	50 pcs.	<b>39420</b>
	Isotop® MSN 8 CDC	90	883	3.5 Hz	50 pcs.	<b>39421</b>
<b>Height adjustment for MSN/DMSN</b> 	Isotop® NV 1-8 MSN	M8	for MSN/DMSN 1 to 8		1 set (= 4 pcs.)	<b>40507</b>

### Isotop® MSN (unladen)

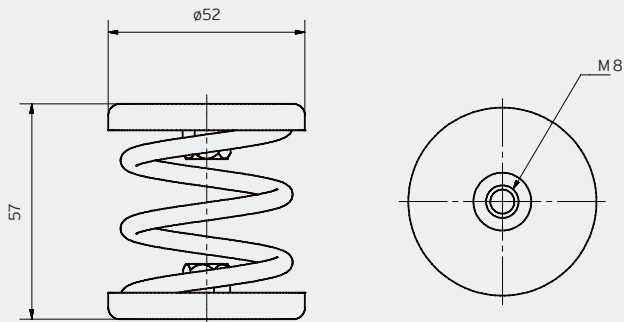

### Isotop® NV 1-8 MSN

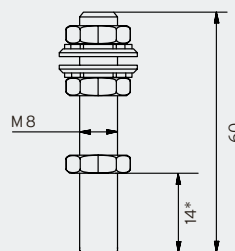

\*Thread reach MSN/DMSN



Axial fan in an AC system



External unit of a heat pump on a wall bracket

**Isotop® MSN 1– MSN 4**

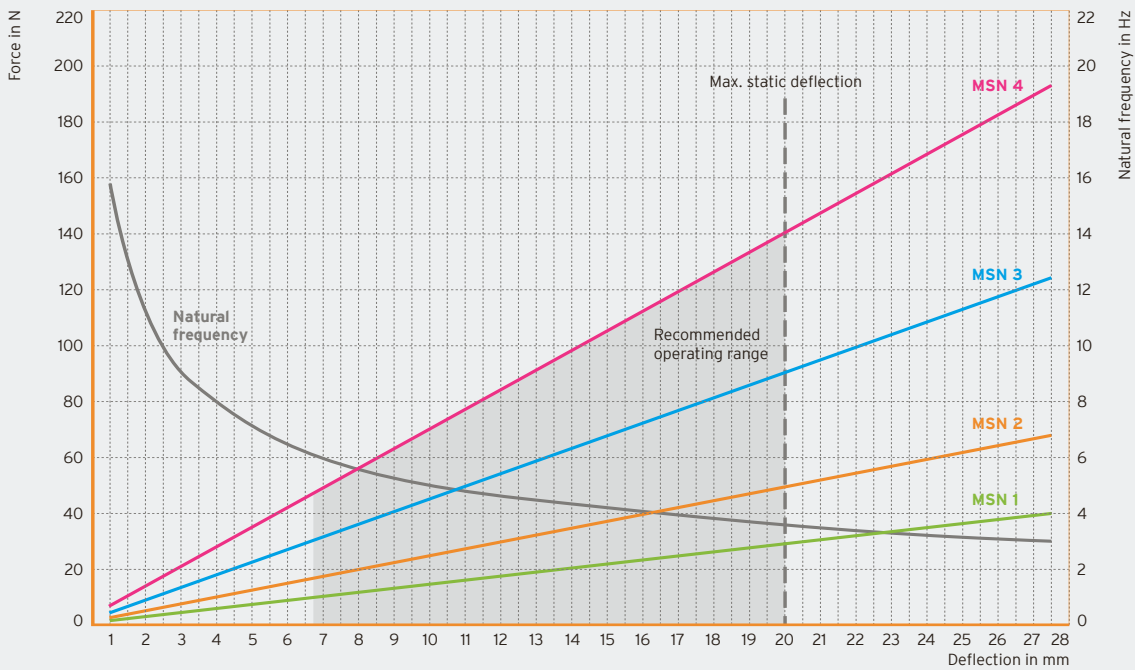

**Isotop® MSN 5– MSN 8**

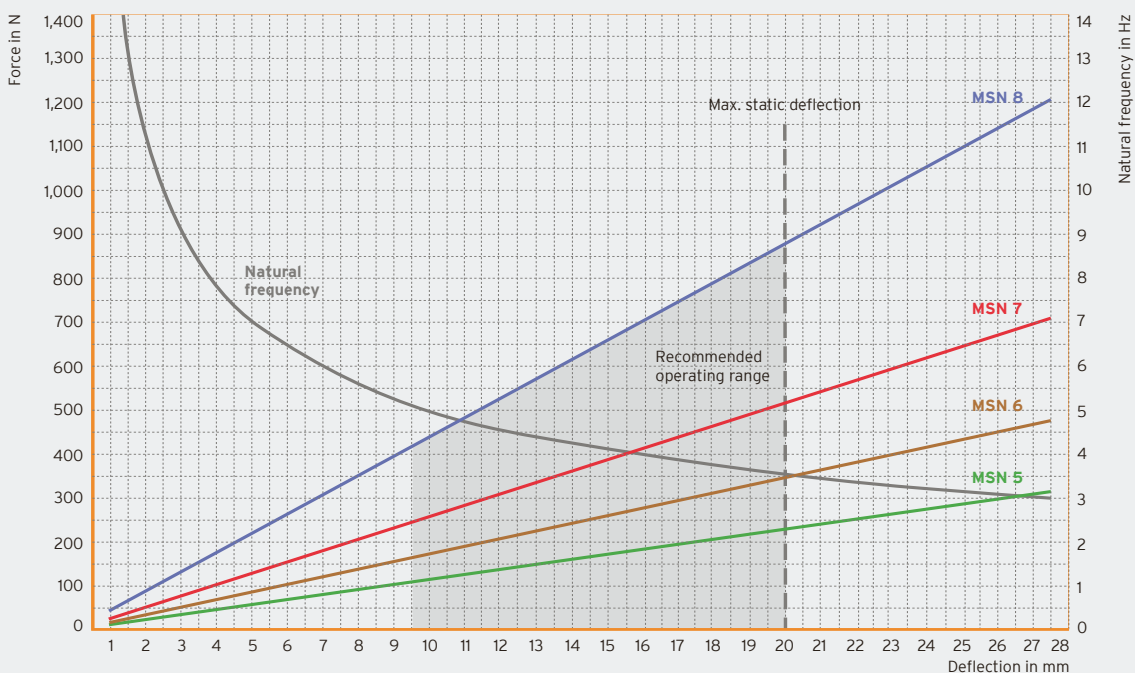

Ota yhteyttä: Christian Berner Oy +358 9 2766 830 • infofi@christianberner.com • www.christianberner.fi

DB Isotop® en © Copyright by Getzner Werkstoffe GmbH 05/2020 | All information and data is based on our current knowledge. The data can be applied for calculations and as guidelines, are subject to typical manufacturing tolerances and are not guaranteed. Material properties as well as their tolerances can vary depending on type of application or use and are available from Getzner on request. Further information can be found in VDI Guideline 2062 (Association of German Engineers) as well as in glossary. Further characteristic values on request.