

**Presión**

**PG30-F1**

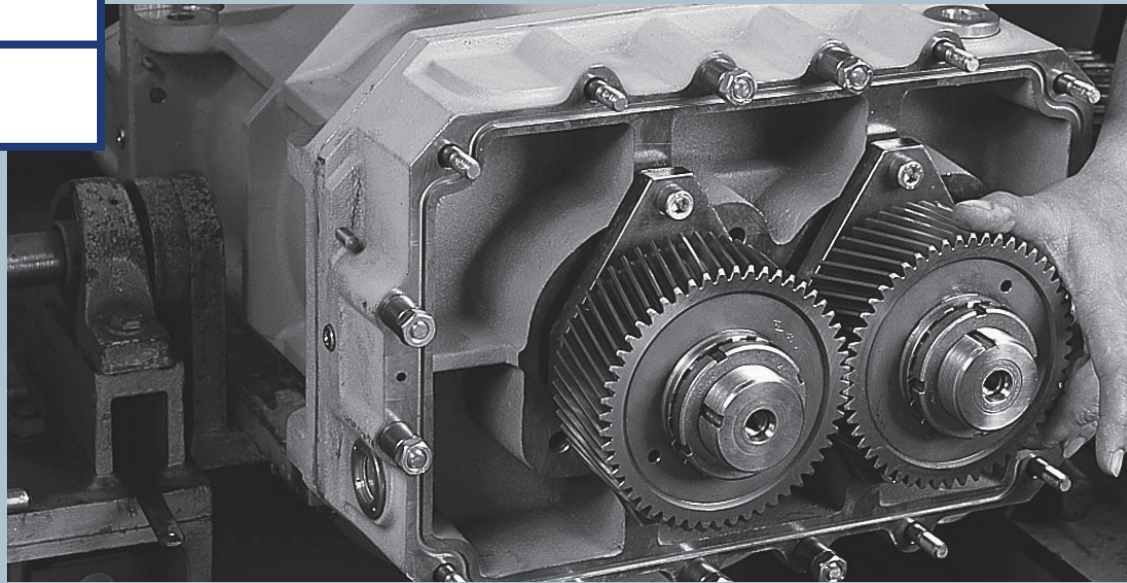

**Soplantes**

—

**Blowers**





**PEDRO GIL, S.L.** desarrolla sus actividades a escala mundial y cuenta con instalaciones en Barcelona y Shanghai.

**PEDRO GIL**, celebró su centenario en 1997 y es reconocida internacionalmente como fabricante de Soplantes rotativos "Roots" y Bombas de Vacío, así como de Sistemas de Vacío. Somos herederos de una historia y una cultura basadas en los principios del servicio al Cliente y la búsqueda de la excelencia.

***PEDRO GIL, S.L.** has a worldwide presence with facilities in Barcelona and Shanghai.*

***PEDRO GIL** celebrates the century on 1997 and is worldwide well known as a manufacture of Roots blowers, vacuum pumps and vacuum systems. Our mission is giving the best service to the customer, and pursuit the excellence.*

## Presión

PG30-F1

### Grupo Soplante Más rapidez para su equipo de mantenimiento.

Alguien tiene que ser el primero. Pedro Gil lanza los nuevos soplantes pensados para un mantenimiento más rápido, cómodo y eficaz.

La cabina insonorizante con puertas, se abre dejando a la vista el grupo soplante para hacer el mantenimiento regular, que se hacen con la misma rapidez que en un F-1.

Es posible instalar varios grupos en batería sin interferencia entre ellos ahorrando espacio y con total accesibilidad de manipulación.

El nuevo diseño de la cabina facilita también el desplazamiento del grupo.

Pregunte a su mecánico de mantenimiento, verá como todo son ventajas.

### Blower Group More speed for your maintenance team.

*Someone has to be the first. Pedro Gil launches new blowers designed for a faster maintenance more comfortable and more effective.*

*The opened insulating cabin doors, leave the main parts of the blower reachable for a maintenance as fast as F1 car.*

*It is possible to install several groups in battery without interference saving space and having a complete access for maintenance.*

*The new cabin design also improves the group shifting from one place to another.*

*Ask your maintenance team about these advantages.*

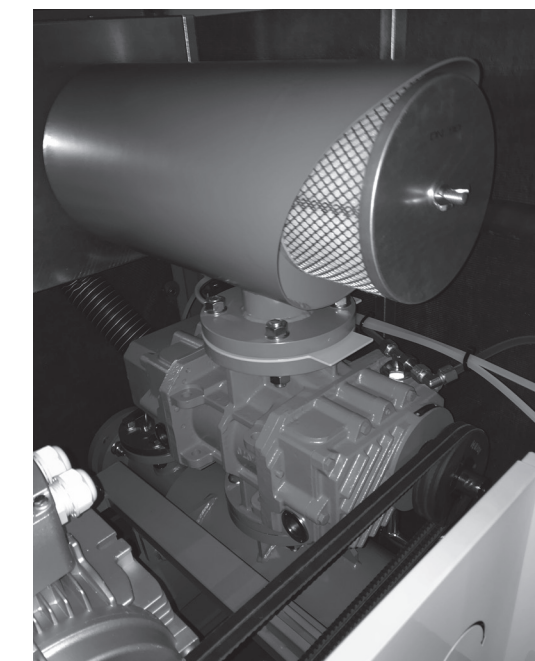



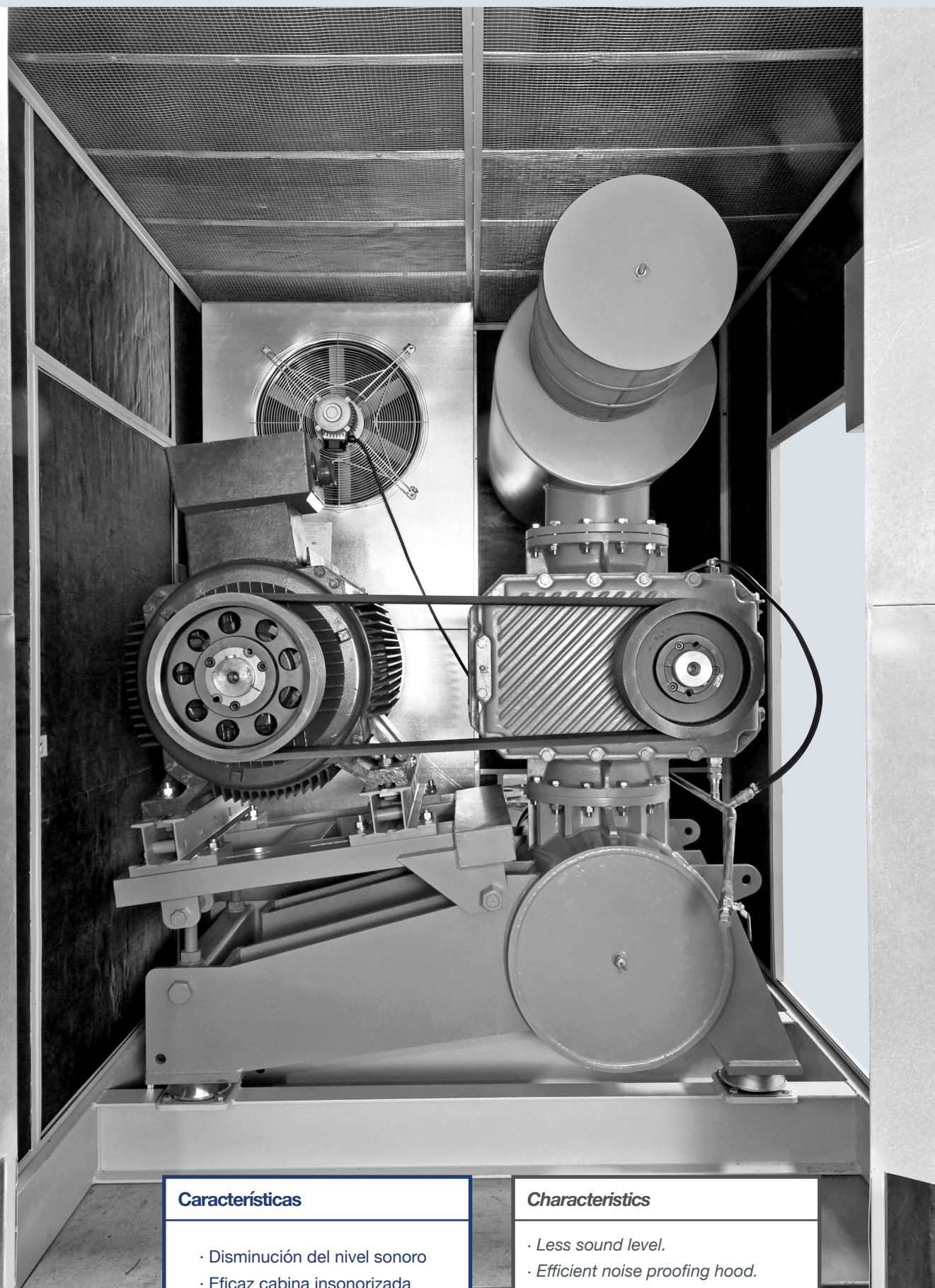

**Características**

- Disminución del nivel sonoro
- Eficaz cabina insonorizada
- Menos vibraciones
- Compacto para ahorrar espacio.

**Characteristics**

- Less sound level.
- Efficient noise proofing hood.
- Less vibration.
- Compact in order to have more space

## Puntos destacables

- 1 Accesibilidad**  
Mejora del acceso a los puntos principales de mantenimiento.
- 2 Mantenimiento**  
Nuevos registros de mantenimiento, localizados en los paneles delanteros y traseros de la cabina, de forma que se pueden instalar los grupos soplantes sin separación en el lateral, lo cual permite optimizar espacio.
- 3 Información a la vista**  
Nuevo panel de control electrónico para la medición de temperatura, presión, vibraciones, nivel de aceite (conexión intranet opcional).
- 4 Niveles**  
Nivel de aceite visible desde el exterior de la cabina.
- 5 Cambios**  
Cambio rápido cartucho filtrante, con solo abrir una puerta de la cabina.
- 6 Cambio de aceite**  
Sistema para facilitar el llenado y vaciado de aceite, de forma cómoda, fiable y rápida.
- 7 Correas**  
Tensado fácil de correas, sin necesidad de desmontar la cabina.
- 8 Cerramiento**  
Se incorpora de serie el suelo de la cabina.
- 9 Válvula de seguridad**  
instalada en el flujo de aire del ventilador de aspiración de la cabina.
- 10 Acceso rápido**  
a todas las válvulas, seguridad, retención y de alivio, a través del panel del lado impulsión.
- 11 Traslado fácil**  
La optimización del diseño de la cabina, permite manipular y desplazar la cabina de una forma fácil.

## Highlights

- 1 Accessibility**  
*Improving access to the main points of maintenance*
- 2 Maintenance**  
*New points of maintenance located in the front and rear acoustic hood panels. Allowing to install groups side by side, optimizing space.*
- 3 Electronic panel**  
*New electronic control panel for measuring temperature, pressure, vibration, oil level (Intranet connection is optional).*
- 4 Levels**  
*Oil level visible from outside the acoustic hood.*
- 5 Changes**  
*Quick change of filter cartridge, opening the door of the acoustic hood.*
- 6 Oil change**  
*New oil system for an easy filling and emptying.*
- 7 Belts**  
*Easily tension without having to dismantle the acoustic hood.*
- 8 Acoustic hood floor**  
*It is included for an easy transport.*
- 9 Safety valve**  
*Installed in airflow fan aspiration.*
- 10 Quick access**  
*to all valves (safety check and unloaded) through impulse side panel.*
- 11 Easy move**  
*The new acoustic hood design allows an easy handling.*



## Nueva línea de cambio rápido

## New fast change line



**Acceso rápido a todos los puntos de mantenimiento**

**Quick access to all maintenance points**



**Filtro de aire**  
**Air filter**

5 min.

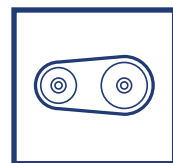

**Tensado y cambio de correas**

**Tension and change belt**

15 min.



**Nivel de aceite, vaciado y llenado**  
**Level of oil, emptying and filling**

2 min.



**Válvula de seguridad, de retención y de alivio con silenciador incorporado**

**Safety valve, retention and relief with silencer incorporated**

En el tamaño medio de soplantes, tiempos promedio.

## Características constructivas

**Cada grupo PG-30 incorpora, de serie, los siguientes materiales:**

- Un soplante trilobular RNT.
- Un filtro-silenciador, en aspiración.
- Un bastidor, que a su vez es un silenciador reactivo de impulsión, totalmente metálico y ecológico.
- El accionamiento previsto mediante un motor eléctrico y la transmisión por correas y poleas con taper-lock.
- Una protección de la transmisión de acero, incluso con cabina de insonorización.
- Una válvula de seguridad, capaz de evacuar todo el aire, en el caso de sobrepresión.
- Una válvula de retención que protege el grupo soplante contra cualquier retorno, a través de la tubería de impulsión.
- La conexión del grupo soplante al sistema se realiza mediante manguito de goma de neopreno.
- Todo el grupo se apoya sobre pies elásticos antivibratorios.
- Sistema de llenado y de vaciado de aceite.

### Accesorios opcionales:

- Cabina insonorizante
- Compensador axial, recomendado a partir de presiones superiores a 0,7 bar (g). Su aplicación sustituye al manguito de goma.
- Válvula de alivio, la cual se recomienda para los casos en los que el arranque sea con carga.
- Manómetro de impulsión para el control de la presión.
- Varios tal como: presostatos, termostatos, termómetros, etc.
- Indicador mantenimiento filtro.
- Panel electrónico de control: presión, temperatura, vibraciones.

## Construction features

**The standard PG-30 group includes:**

- A three lobes blower.
- The air filter-silencer, connected on the blower's inlet flange.
- The reactive silencer placed on the outlet side. It is metallic and ecological. It is also the base-frame for the blower and motor.
- The drive is by an electrical motor through v-belts and pulleys (taper-lock system).
- The belt guard is made from steel sheet also with acoustic hood.
- The relief valve designed to evacuate air or gas when the pressure is over.
- The check valve protects the blower against a back pressure when the blower stops and the pipe is pressurized.
- The flexible rubber sleeve with clamps connects the group with the pipe.
- Filling and emptying oil system.
- The elastic feet, support the group.

### Optional accessories:

- Noise proofing hood.
- Axial compensator. It is recommended for pressures over 0,7 bar. It is instead the rubber sleeve.
- Unloading valve. When the pipe is pressurized, is recommended to use this valve and obtain a progressive start.
- Others could be: gauges, thermometer, switch, frequency converter, etc.
- Air filter gauge.
- Digital control panel: pressure, temperature, vibration.





## Aplicaciones técnicas

---

- Depuradoras de agua
  - Transporte neumático
  - Aspiradores industriales
  - Aireación de piscifactorías
  - Aportación de aire para quemadores
  - Industria textil
  - Industria papelera
  - Fluidificación
  - Vehiculación de gases no explosivos
- 

Como aplicaciones más significativas.

Nuestro amplio programa de fabricación ofrece múltiples combinaciones adaptables a cada necesidad.

No dude en contactar con nuestro Departamento Técnico, donde estudiarán su solicitud para elegir la mejor solución técnica y económica a su proyecto.

## Technical applications

---

- Water treatment plants
  - Pneumatic transport
  - Industrial vacuum airing equipment
  - Fish farm
  - Air supply for burners
  - Textile industry
  - Paper industry
  - Fluidification beds
  - Non-explosive gas transfer
- 

These are the most significant options.

Our wide manufacturing program offers a great number of combinations that can be adjusted to every need.

Please do not hesitate to contact our Technical Department who will study your request in detail and offer you the optimum technical and economical solution.



## Información técnica Technical information

## PG 30 - F1

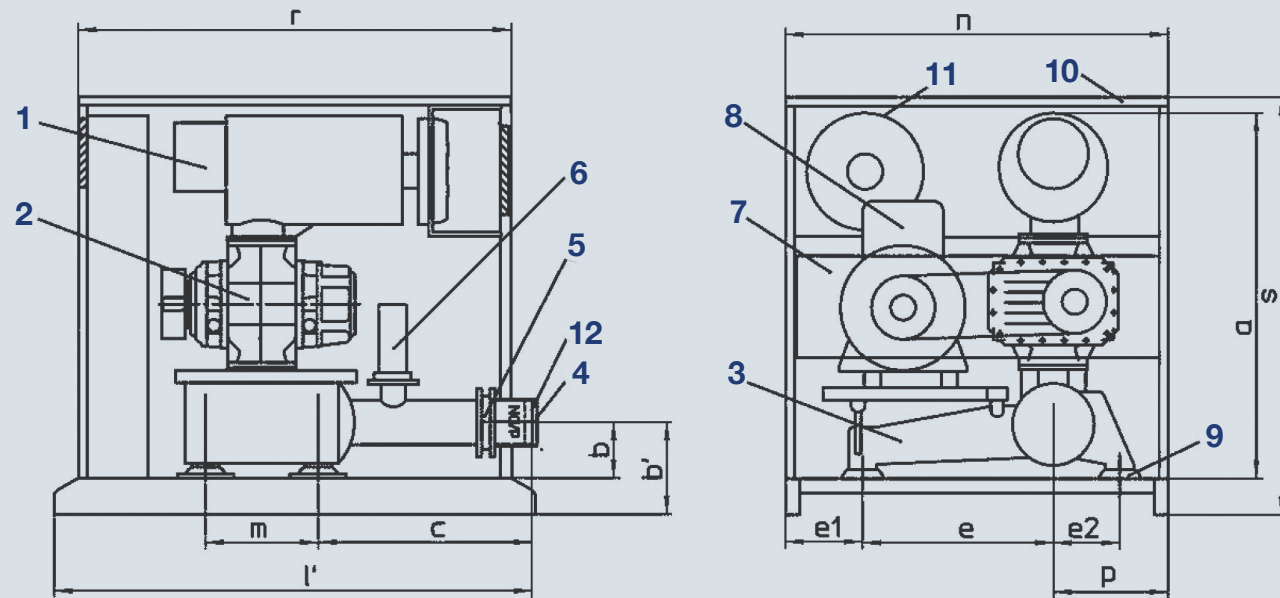

- 1 Filtro aspiración - Inlet Filter
- 2 Soplante - Blower
- 3 Silenciador bancada - Frame Silencer
- 4 Manguito - Rubber sleeve
- 5 Válvula de retención - Check valve
- 6 Válvula de seguridad - Relief Valve

- 7 Protección transmisión - Protection guard
- 8 Motor eléctrico - Electrical motor
- 9 Pies elásticos - Elastic feet
- 10 Cabina insonorización - Acoustic hood
- 11 Ventilador eléctrico - Electrical fan
- 12 Tubo brida - Connecting pipe with flange

Tamaño Size	DN	Motor máx. Max. Motor	d	a	b	b'	c	m	e1	e	e2	p	l'	n	r	s	Ventilador Fan (Kw)	Grupo s/mot Group w/mot	Cabina Cabin
30.05	50	7,5/132S	60,3	950	148	306	465	411	285	455	170	280	1255	1020	1160	1195	0,25	165	165
30.10	50	11/160M	60,3	950	148	306	435	411	285	455	170	280	1195	1020	1160	1195	0,25	165	165
30.20	80	15/160M	88,9	950	148	306	435	411	285	455	170	280	1195	1020	1160	1195	0,25	225	165
30.30	80	18,5/160L	88,9	950	148	306	435	411	285	455	170	280	1195	1020	1160	1195	0,25	230	165
31.10	80	18,5/160L	88,9	950	148	306	435	411	285	455	170	280	1195	1020	1160	1195	0,25	230	165
31.20	100	30/200L	114,3	1150	175	333	611	542	320	640	200	320	1530	1280	1440	1494	0,75	330	250
31.30	100	30/200L	114,3	1150	175	333	611	542	320	640	200	320	1530	1280	1440	1494	0,75	360	250
32.10	100	37/200L	114,3	1150	175	333	611	542	320	640	200	320	1530	1280	1480	1494	0,75	400	250
32.20	100	55/250M	114,3	1150	175	333	611	542	320	640	200	320	1530	1280	1440	1494	0,75	420	250
32.20	150	55/250M	168,3	1500	232	390	780	460	370	745	245	395	1890	1500	1840	1748	0,75	580	400
32.30	150	75/250M	168,3	1500	232	390	780	460	370	745	245	395	1890	1500	1840	1748	0,75	600	400
33.10	150	75/250M	168,3	1500	390	780	460	370	745	745	245	395	1890	1500	1840	1745	0,75	665	400
33.20	150	90/280S	168,3	1500	232	390	780	460	370	745	245	395	1890	1500	1840	1748	0,75	695	400
33.30	150	90/280M	168,3	1500	232	390	780	460	370	745	245	395	1890	1500	1840	1748	0,75	745	400
33.30	200	90/280M	219,1	1850	254	454	1080	600	310	948	330	643	2460	1870	2200	2144	1,1	800	1050
34.10	200	90/280M	219,1	1850	254	454	1080	600	310	948	330	643	2460	1870	2200	2144	1,1	920	1050
34.20	200	132/315M	219,1	1850	254	454	1080	600	310	948	330	643	2460	1870	2200	2144	1,1	960	1050
34.30	200	132/315M	219,1	1850	254	454	1080	600	310	948	330	643	2460	1870	2200	2144	1,1	110	1050
34.30	250	132/315M	273,0	2070	311	526	1005	560	270	1120	310	580	2665	1970	2550	2445	1,1	1600	1275
35.10	200	132/315M	219,1	1850	254	454	1080	600	310	948	330	643	2460	1870	2200	2144	1,1	1280	1050
35.10	250	160/315L	273,0	2070	311	526	1005	560	270	1120	310	580	2665	1970	2550	2445	1,1	1650	1275
36.10	250	160/315L	273,0	2070	311	526	1005	560	270	1120	310	580	2665	1970	2550	2445	1,1	2100	1275
36.20	300	315/355L	324,0	2360	416	651	1286	590	373	1192	400	743	2907	2300	2650	2695	1,5	2600	1500

## Cabina insonorización Menos ruido

Las normativas acústicas vigentes se han convertido en un elemento indispensable en la mayoría de ambientes de trabajo. PG ha realizado estudios acústicos mejorando sensiblemente este producto y facilitando las funciones de mantenimiento del grupo soplante con la cabina instalada.

Las cabinas se construyen con paneles de chapa galvanizada. Cada panel incorpora en su interior material fonoabsorbente, la parte de acceso para mantenimiento, esta dotada con una puerta que al abrirla, se accede fácilmente a los puntos de mantenimiento. El acceso se realiza desde la parte frontal, con lo que las cabinas se pueden instalar juntas una al lado de otra ahorrando espacio de esta forma.

El resto de paneles que componen la cabina son desmontables. Todas las cabinas incorporan suelo para facilitar el transporte y la manipulación.

Igualmente, incorporan un ventilador eléctrico helicoidal compacto para disipar el calor del interior de la cabina.

Las cabinas de tamaños DN-250 y 300, se suministran con puertas laterales, además de la puerta frontal.

Todas las cabinas incorporan un sistema de llenado de aceite y control de nivel desde el exterior.

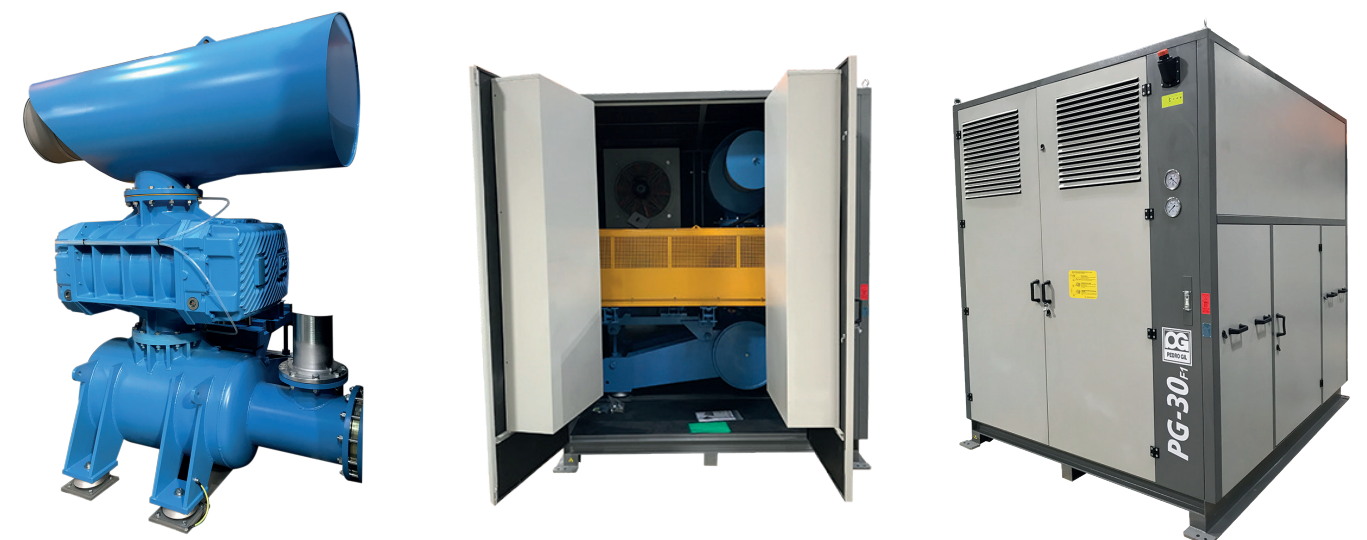

## Sound proofing hood Less noise

The sound proofing hood has turned into an essential element in most working environments in order to follow the current acoustic regulations. PG has performed acoustic tests improving this product noticeably.

They are built from modular panels from galvanized metal sheet. The inner side of each acoustic panel is lined with self-extinguishable polyester absorbing material covered with a waterproof film. The maintenance panel has a door to accede to maintenance points, and it is situated in the front part of the acoustic hood in order to install the groups side by side saving space.

The rest of the panels are dismantlable. All acoustic hoods have floor to improve its handling.

They also include a compact helicoidal electric fan, to dissipate the heat generated inside the acoustic hood.

The acoustic hood sizes DN-250 and DN-300 are delivered lateral doors besides the frontal ones.

All the acoustic hoods have a filling and emptying oil system with an external oil sight glass.



## Información técnica Technical information

### Soplante émbolos rotativos Eje libre Tipo RNT Ejecución B-5

### Rotary piston blower Free shaft Type RNT Form B-5

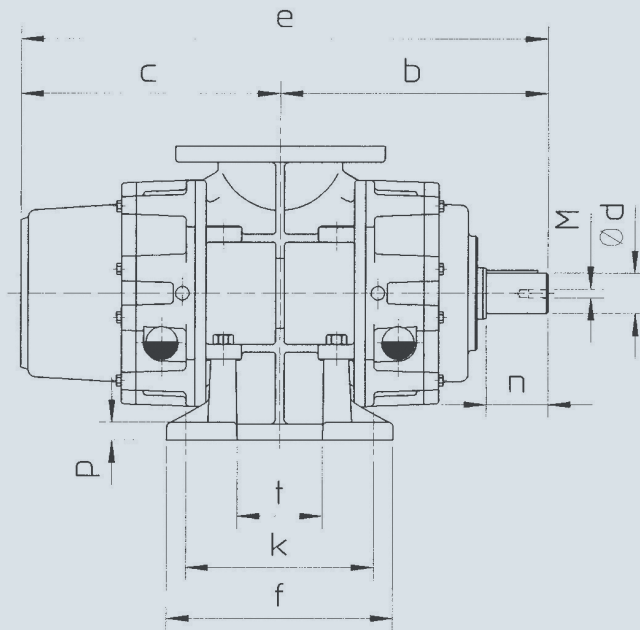
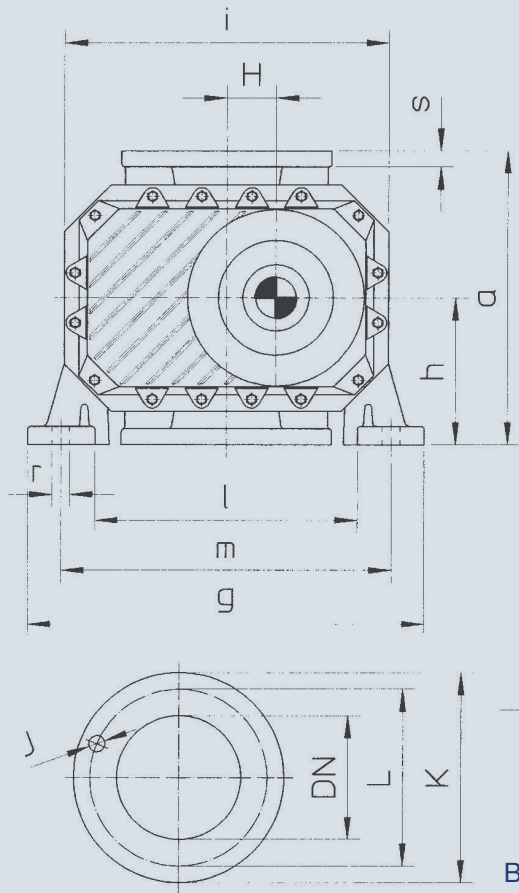

Chaveta / Fitting key as DIN 6885  
Tolerancia ejes / Shaft tolerance up to  
<math>\varnothing 50</math> ISA k6; <math>\varnothing 50</math> ISA k6

Bridas / Flages DIN 2532

Tamaño Size	DN	a	b	c	ød	e	f	g	h	i	k	l	m	n	p	r	s	t	u	v	H	J		K	L	M	Peso Weight (kg)
																						ø	n°				
30.05	50	276	221	200	28	421	68	313	138	264	33	197	253	84	18	14	18	-	31	8	37,5	18	4	165	125	M8	60
30.10	50	276	241	220	28	461	148	313	138	264	118	197	253	84	18	14	18	11	31	8	37,5	18	4	165	125	M8	67
30.20	80	276	261	240	28	501	188	313	138	264	158	197	253	84	20	14	20	51	31	8	37,5	18	4	200	160	M8	75
30.30	80	276	286	265	28	551	238	313	138	264	207	197	253	84	20	14	20	101	31	8	37,5	18	4	200	160	M8	85
31.10	80	320	296	263	38	559	214	366	160	300	174	202	290	88	20	18	20	60	41,4	10	43	18	4	200	160	M8	95
31.20	100	320	323	291	38	614	270	366	160	294	230	202	290	88	20	18	19	114	41,4	10	43	18	8	220	180	M8	112
31.30	100	320	374	341	38	715	370	366	160	300	330	202	290	88	20	18	20	216	41,4	10	43	18	8	220	180	M8	132
32.10	100	350	338	305	45	643	249	426	175	370	202	266	354	103	23	18	20	71	48,6	14	53	18	8	220	180	M12	175
32.20	100	350	378	345	45	723	328	426	175	370	282	266	354	103	23	18	20	152	48,6	14	53	18	8	220	180	M12	198
32.30	150	350	434	401	45	835	440	426	175	370	394	266	354	103	23	18	20	264	48,6	14	53	23	8	285	240	M12	236
33.10	150	400	381	345	55	726	303	529	200	452	253	347	444	143	25	24	22	113	58,6	16	67	23	8	285	240	M12	280
33.20	150	400	434	398	55	832	409	529	200	452	359	347	444	143	25	24	22	219	58,9	16	67	23	8	285	240	M12	315
33.30	150	400	504	467	55	971	549	529	200	452	499	347	444	143	25	24	22	359	58,9	16	67	23	8	285	240	M12	373
34.10	150	500	481	424	60	905	252	592	250	544	177	404	528	145	40	24	22	102	64,3	18	85	23	8	285	240	M20	390
34.20	200	500	537	479	60	1.016	363	592	250	544	288	404	528	145	40	24	26	213	64,3	18	85	23	8	340	295	M20	428
34.30	200	500	627	570	60	1.197	539	592	250	544	464	404	528	145	40	24	26	389	64,3	18	85	23	8	340	295	M20	455
35.10	200	630	522	468	70	990	329	728	315	644	249	488	638	150	45	24	27	169	74,7	20	106	23	8	340	295	M20	600
35.20	250	630	586	532	70	1.094	458	728	315	644	378	488	638	150	45	24	27	298	74,7	20	106	23	12	395	350	M20	670
36.10	250	780	653	550	90	1.203	390	948	390	810	280	628	846	190	55	24	27	170	95,4	25	135	23	12	395	350	M24	1.220
36.20	300	780	769	665	90	1.434	620	948	390	810	510	628	848	190	55	24	27	400	95,4	25	135	23	12	445	400	M24	1.400

## Soplante RNT Trilobular de baja pulsación y alta frecuencia

### Características constructivas

Los pistones rotativos son de tres lóbulos cerrados y equilibrados dinámicamente dentro de un cuerpo de fundición. Este cuerpo incorpora en la parte de impulsión, un sistema específico, con lo que se consigue una compresión progresiva y en consecuencia, una reducción de la pulsación en el punto donde se genera. Los engranajes son de dentado helicoidal tratados térmicamente y rectificadas según DIN-6.

El calado sobre el eje es cónico, sin chaveta. La lubricación, tanto de los engranajes como de los rodamientos, es por barboteo de aceite. La estanqueidad entre la cámara de compresión y los cárter se consigue mediante cierre laberíntico con segmentos y cámara intermedia de condensados. La estanqueidad del eje de accionamiento con el exterior se consigue mediante una junta radial de labio (Retén).

## RNT Blower Three lobes blower with low pulsation and high frequency

### Construction features

This blower is provided with three lobe rotors, closed and dynamically balanced. Housed in a cast iron cylinder which has an specific system on the outlet side that obtains a progressive compression and, consequently, a reduction of the pulsation at the point where it starts. Helical gears hardened and ground according DIN-6.

The fitting on the shaft is conical. Oil splash provides lubrication to both gears and bearings. The sealing between the cylinder and oil housings is through, labyrinth segment seal and intermediare condenser haes. A radial lip seal guarantees the drive shaft sealing.

Materiales de construcción	
Cuerpo Laterales intermedios Cárter	Fundición GG-25
Pistón-Eje Tamaños 30.05 a 33.30	Acero forjado CK-45
Pistones Tamaños 34.10 a 36.20	Fundición nodular GGG-50
Ejes Tamaños 34.10 a 36.20	Acero CK-45
Engranajes	Acero 18 Cr Mo4

Manufacturing materials	
Cylinder Headplate Gear & Bearing housing	Cast iron GG-25
Shaft-Piston Sizes 30.05 to 33.30	Forged steel CK-45
Pistons Sizes 34.10 to 36.20	Cast iron nodular GGG-50
Shafts Sizes 34.10 to 36.20	Steel CK-45
Gears	Steel 18 Cr Mo4

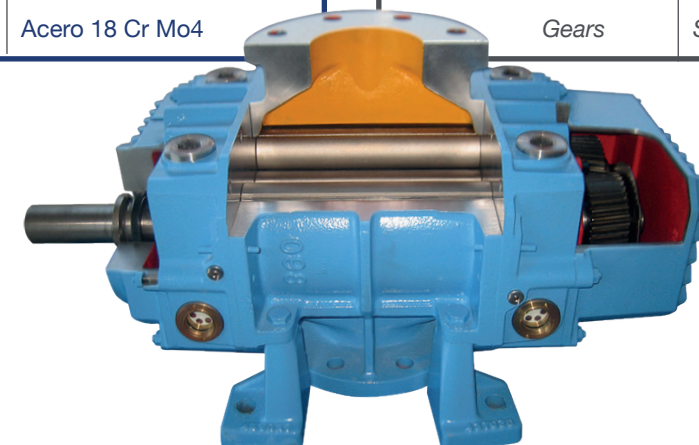



# Información técnica

## Technical information

### PG 30 - F1

# Consultar cuando se requieran presiones y caudales no contemplados.  
Ask when requested pressures and intake capacities are not shown.

Δp/mbar	Tamaño / Size	30.05 / DN - 50										
		Q1	m3/min	0,34	0,70	1,06	1,42	1,71	2,07	2,36	2,57	2,79
300	Q1	m3/min	0,34	0,70	1,06	1,42	1,71	2,07	2,36	2,57	2,79	
	Δt	°C	73	48	40	36	34	33	32	31	31	
	R.P.M	sopl.	1400	1900	2400	2900	3300	3800	4200	4500	4800	
	R.P.M	mtr.	2860	2850	2850	2895	2895	2895	2895	2895	2910	
	Kw	N.abs Kw		0,9	1,22	1,53	1,85	2,11	2,43	2,69	2,88	3,07
			N.motor	1,1	1,5	2,2	3	3	4	4	4	4
dB(A)	s.cab.		66	68	72	75	77	79	82	84	85	
		c.cab.	63	63	64	64	64	64	64	65	65	
400	Q1	m3/min	0,31	0,6	0,96	1,32	1,61	1,97	2,25	2,47	2,68	
	Δt	°C	114	75	59	52	49	46	44	43	42	
	R.P.M	sopl.	1500	1900	2400	2900	3300	3800	4200	4500	4800	
	R.P.M	mtr.	2860	2850	2895	2895	2895	2895	2910	2910	2910	
	Kw	N.abs Kw		1,14	1,44	1,82	2,2	2,51	2,89	3,19	3,42	3,64
			N.motor	1,5	2,2	2,2	3	3	4	4	5,5	5,5
dB(A)	s.cab.		68	70	72	77	80	82	85	86	86	
		c.cab.	63	63	63	63	64	64	64	67	67	
500	Q1	m3/min	0,51	0,87	1,23	1,52	1,87	2,16	2,38	2,59		
	Δt	°C	111	82	70	65	60	58	56	55		
	R.P.M	sopl.	1900	2400	2900	3300	3800	4200	4500	4800		
	R.P.M	mtr.	2895	2895	2895	2895	2910	2910	2910	2910		
	Kw	N.abs Kw		1,67	2,11	2,55	2,9	3,34	3,69	3,96	4,22	
			N.motor	2,2	3	3	4	5,5	5,5	5,5	5,5	
dB(A)	s.cab.		71	74	78	80	82	85	87	87		
		c.cab.	64	64	65	65	65	68	68	69		
600	Q1	m3/min	0,71	0,93	1,15	1,43	1,79	2,08	2,3	2,51		
	Δt	°C	115	100	90	82	76	72	70	68		
	R.P.M	sopl.	2300	2600	2900	3300	3800	4200	4500	4800		
	R.P.M	mtr.	2895	2895	2895	2910	2910	2910	2910	2910		
	Kw	N.abs Kw		2,3	2,6	2,9	3,3	3,8	4,2	4,5	4,8	
			N.motor	3	4	4	5,5	5,5	7,5	7,5	7,5	
dB(A)	s.cab.		74	75	79	80	83	85	87	87		
		c.cab.	64	65	65	65	66	68	69	69		
700	Q1	m3/min	1,07	1,36	1,72	2,01	2,22	2,44				
	Δt	°C	113	101	92	87	84	82				
	R.P.M	sopl.	2900	3300	3800	4200	4500	4800				
	R.P.M	mtr.	2910	2910	2910	2910	2910	2910				
	Kw	N.abs Kw		3,24	3,69	4,25	4,7	5,03	5,37			
			N.motor	4	5,5	5,5	7,5	7,5	7,5			
dB(A)	s.cab.		82	83	86	87	88	88				
		c.cab.	65	66	68	69	70	70				

- Características referidas a: δ=1,2 Kg/m³ (P1=1 bar abs. t1=20oC)  
- Tolerancia de caudal y potencia absorbida: ± 5%  
- Nivel sonoro medio en campo abierto a 1m. de distancia Tolerancia: ± 2dB(A)  
- Δt °C = incremento de temperatura

- Performance data refer to: δ=1,2 Kg/m³ (P1=1 bar abs. t1=20oC)  
- Tolerance for inlet flow and absorbed power: ± 5%  
- Noise level refer to out door measurements at a distance of 1m. Tolerance: ± 2dB(A)  
- Δt °C = increase of temperature

# Información técnica

## Technical information

### PG 30 - F1

# Consultar cuando se requieran presiones y caudales no contemplados.  
Ask when requested pressures and intake capacities are not shown.

Δp/mbar	Tamaño / Size	30.10 / DN-50						30.20 / DN-80						30.30 / DN-80							
		Q1	m3/min	0,74	1,87	2,43	3,45	4,24	4,58	1,15	2,7	3,47	4,87	5,95	6,42	1,55	3,62	4,66	6,52	7,97	8,59
300	Q1	m3/min	0,74	1,87	2,43	3,45	4,24	4,58	1,15	2,7	3,47	4,87	5,95	6,42	1,55	3,62	4,66	6,52	7,97	8,59	
	Δt	°C	53	36	34	31	30	30	47	34	32	30	29	29	47	34	32	30	29	29	
	R.P.M	sopl.	1400	2400	2900	3800	4500	4800	1400	2400	2900	3800	4500	4800	1400	2400	2900	3800	4500	4800	
	R.P.M	mtr.	2860	2850	2895	2895	2895	2910	2850	2895	2895	2895	2910	2910	2850	2895	2910	2910	2910	2910	
	Kw	N.abs Kw		1	1,7	2	2,6	3,1	3,3	1,3	2,3	2,8	3,6	4,3	4,6	1,7	2,9	3,5	4,6	5,4	5,8
			N.motor	1,5	2,2	3	3	4	5,5	2,2	3	3	4	5,5	5,5	2,2	4	5,5	7,5	7,5	7,5
dB(A)	s.cab.		66	72	75	79	83	85	68	74	77	80	83	84	73	78	79	82	86	86	
		c.cab.	63	63	64	64	65	65	63	64	64	64	65	65	64	65	65	66	67	67	
400	Q1	m3/min	0,61	1,74	2,3	3,32	4,11	4,45	0,99	2,54	3,31	4,71	5,79	6,26	1,34	3,41	4,45	6,31	7,76	8,38	
	Δt	°C	86	52	47	43	41	40	73	49	45	42	40	39	72	48	45	41	40	39	
	R.P.M	sopl.	1400	2400	2900	3800	4500	4800	1400	2400	2900	3800	4500	4800	1400	2400	2900	3800	4500	4800	
	R.P.M	mtr.	2860	2895	2895	2895	2910	2910	2850	2895	2895	2910	2910	2910	2895	2910	2910	2910	2915	2915	
	Kw	N.abs Kw		1,2	2,1	2,6	3,3	4	4,2	1,7	2,9	3,5	4,6	5,4	5,8	2,2	3,7	4,5	5,9	7	7,5
			N.motor	1,5	3	3	4	5,5	5,5	2,2	3	4	5,5	7,5	7,5	3	5,5	5,5	7,5	11	11
dB(A)	s.cab.		66	72	75	79	84	85	68	75	78	80	84	85	74	78	80	83	88	88	
		c.cab.	63	64	64	64	65	65	63	64	64	64	65	65	65	65	66	67	68	68	
500	Q1	m3/min	1,62	2,19	3,2	4	4,33	0,85	2,4	3,17	4,57	5,65	6,12	1,16	3,23	4,26	6,13	7,58	8,2		
	Δt	°C	69	62	56	53	52	106	64	59	54	51	50	104	64	58	53	51	50		
	R.P.M	sopl.	2400	2900	3800	4500	4800	1400	2400	2900	3800	4500	4800	1400	2400	2900	3800	4500	4800		
	R.P.M	mtr.	2895	2895	2910	2910	2910	2895	2895	2910	2910	2910	2910	2895	2910	2910	2915	2915	2915		
	Kw	N.abs Kw		2,6	3,1	4,1	4,8	5,1	2,1	3,5	4,3	5,6	6,6	7	2,7	4,6	5,5	7,2	8,6	9,1	
			N.motor	3	4	5,5	7,5	7,5	3	4	5,5	7,5	7,5	7,5	4	5,5	7,5	11	11	11	
dB(A)	s.cab.		72	77	82	86	86	69	75	78	80	85	85	75	78	80	84	87	87		
		c.cab.	63	63	64	67	67	63	64	64	64	65	65	65	65	66	67	69	69		
600	Q1	m3/min	1,52	2,08	3,1	3,89	4,23	2,27	3,05	4,44	5,53	5,99	3,06	4,1	5,96	7,41	8,03				
	Δt	°C	89	78	69	65	64	82	73	66	63	62	81	73	66	63	62				
	R.P.M	sopl.	2400	2900	3800	4500	4800	2400	2900	3800	4500	4800	2400	2900	3800	4500	4800				
	R.P.M	mtr.	2895	2895	2910	2910	2910	2910	2910	2910	2915	2915	2910	2910	2915	2925	2925				
	Kw	N.abs Kw		3	3,6	4,8	5,7	6	4,1	5	6,6	7,8	8,3	5,4	6,5	8,5	10,1	10,8			
			N.motor	4	4	5,5	7,5	7,5	5,5	5,5	7,5	11	11	7,5	7,5	11	15	15			
dB(A)	s.cab.		74	78	82	87	87	75	78	80	86	86	78	81	85	88	88				
		c.cab.	64	65	65	68	69	64	64	64	65	65	66	67	68	70	70				
700	Q1	m3/min	1,42	1,99	3	3,8	4,13	2,16	2,93	4,33	5,41	5,88	2,91	3,95	5,81	7,26	7,88				
	Δt	°C	111	96	83	78	76	100	89	79	75	74	99	88	79	75	73				
	R.P.M	sopl.	2400	2900	3800	4500	4800	2400	2900	3800	4500	4800	2400	2900	3800	4500	4800				
	R.P.M	mtr.	2895	2910	2910	2910	2910	2910	2910	2910	2915	2915	2910	2915	2915	2925	2925				
	Kw	N.abs Kw		3,5	4,2	5,5	6,5	6,9	4,8	5,8	7,5	8,9	9,5	6,2	7,5	9,8	11,7	12,4			
			N.motor	4	5,5	5,5	7,5	7,5	5,5	7,5	11	11	11	7,5	11	11	15	15			
dB(A)	s.cab.		75	79	83	87	87	75	78	80	86	86	80	82	86	90	90				
		c.cab.	65	65	66	69	69	64	64	64	66	66	67	68	69	72	72				
800	Q1	m3/min	1,9	2,92	3,71	4,05	2,82	4,22	5,3	5,77	3,8	5,67	7,12	7,74							
	Δt	°C	115	98	91	89	106	93	87	86	105	92	87	85							
	R.P.M	sopl.	2900	3800	4500	4800	2900	3800	4500	4800	2900	3800	4500	4800							
	R.P.M	mtr.	2910	2910	2910																



# Información técnica

## Technical information

# PG 30 - F1

# Consultar cuando se requieran presiones y caudales no contemplados.  
Ask when requested pressures and intake capacities are not shown.

Δp/ mbar	Tamaño / Size	31.10 / DN-80						31.20 / DN-100						31.30 / DN-100						
		Q1	m3/min	1,77	3,83	4,87	6,73	8,18	8,8	2,54	5,34	6,74	9,26	11,22	12,06	4,00	8,14	10,21	13,94	16,83
300	Q1	m3/min	1,77	3,83	4,87	6,73	8,18	8,8	2,54	5,34	6,74	9,26	11,22	12,06	4,00	8,14	10,21	13,94	16,83	18,08
	Δt	°C	41	32	30	29	28	28	38	31	30	29	28	28	36	30	29	28	28	27
	R.P.M	sopl.	1400	2400	2900	3800	4500	4800	1400	2400	2900	3800	4500	4800	1400	2400	2900	3800	4500	4800
	R.P.M	mtr.	2895	2910	2910	2910	2915	2915	2895	2910	2910	2910	2915	2915	2895	2910	2915	2915	2925	2925
	Kw	N.abs Kw	1,71	2,93	3,54	4,64	5,49	5,86	2,5	4,3	5,2	6,8	8,1	8,6	3,6	6,1	7,4	9,7	11,5	12,2
	Kw	N.motor	2,2	4	5,5	5,5	7,5	7,5	4	7,5	7,5	7,5	11	11	4	7,5	11	11	15	15
	dB(A)	s.cab.	80	81	82	85	87	88	69	77	78	82	87	87	72	77	80	85	89	90
dB(A)	c.cab.	70	70	70	71	72	73	64	65	65	68	69	69	64	64	66	67	68	68	
400	Q1	m3/min	1,59	3,66	4,69	6,55	8	8,62	2,32	5,12	6,52	9,04	11	11,84	3,72	7,86	9,93	13,66	16,56	17,8
	Δt	°C	60	45	42	40	38	38	56	44	41	39	38	38	52	42	40	38	37	37
	R.P.M	sopl.	1400	2400	2900	3800	4500	4800	1400	2400	2900	3800	4500	4800	1400	2400	2900	3800	4500	4800
	R.P.M	mtr.	2895	2910	2910	2915	2925	2925	2895	2910	2910	2915	2925	2925	2910	2915	2915	2925	2930	2930
	Kw	N.abs Kw	2,19	3,76	4,54	5,95	7,05	7,52	3,2	5,4	6,6	8,6	10,2	10,9	4,5	7,8	9,4	12,3	14,6	15,6
	Kw	N.motor	4	7,5	7,5	11	15	15	4	7,5	7,5	11	15	15	5,5	11	11	15	18,5	18,5
	dB(A)	s.cab.	81	84	84	87	89	89	70	78	79	84	87	88	73	77	81	85	90	91
dB(A)	c.cab.	70	70	71	73	73	74	64	65	66	68	69	70	64	64	66	67	69	69	
500	Q1	m3/min	1,44	3,5	4,54	6,4	7,85	8,47	2,13	4,93	6,33	8,85	10,81	11,65	3,48	7,62	9,69	13,41	16,31	17,55
	Δt	°C	83	58	55	51	49	48	76	57	53	50	48	48	69	54	51	49	47	47
	R.P.M	sopl.	1400	2400	2900	3800	4500	4800	1400	2400	2900	3800	4500	4800	1400	2400	2900	3800	4500	4800
	R.P.M	mtr.	2910	2910	2915	2925	2925	2930	2910	2910	2915	2925	2925	2930	2910	2915	2925	2930	2940	2945
	Kw	N.abs Kw	2,67	4,58	5,54	7,26	8,6	9,17	3,8	6,6	7,9	10,4	12,3	13,1	5,5	9,4	11,4	14,9	17,7	18,9
	Kw	N.motor	5,5	7,5	11	15	15	18,5	5,5	7,5	11	15	15	18,5	7,5	11	15	18,5	22	30
	dB(A)	s.cab.	83	83	84	86	89	90	71	77	80	85	88	89	74	78	82	86	91	91
dB(A)	c.cab.	70	70	72	73	74	74	64	65	67	69	70	71	64	65	66	68	71	71	
600	Q1	m3/min	1,3	3,37	4,4	6,26	7,71	8,33	1,96	4,76	6,16	8,68	10,64	11,48	3,26	7,4	9,47	13,19	16,09	17,33
	Δt	°C	110	73	67	62	60	59	99	70	66	61	59	58	89	67	63	59	58	57
	R.P.M	sopl.	1400	2400	2900	3800	4500	4800	1400	2400	2900	3800	4500	4800	1400	2400	2900	3800	4500	4800
	R.P.M	mtr.	2910	2915	2915	2925	2930	2930	2910	2915	2915	2925	2930	2930	2910	2925	2925	2940	2945	2945
	Kw	N.abs Kw	3,16	5,41	6,54	8,57	10,15	10,82	4,5	7,7	9,3	12,2	14,4	15,4	6,5	11,1	13,4	17,6	20,8	22,2
	Kw	N.motor	5,5	11	11	15	18,5	18,5	5,5	11	11	15	18,5	18,5	7,5	15	15	22	30	30
	dB(A)	s.cab.	81	82	83	89	90	90	71	77	80	86	89	90	75	80	84	88	93	94
dB(A)	c.cab.	72	72	73	73	74	74	64	65	67	70	71	72	64	66	68	70	72	73	
700	Q1	m3/min		3,24	4,27	6,13	7,58	8,2		4,61	6,01	8,53	10,49	11,33	3,05	7,19	9,26	12,99	15,89	17,13
	Δt	°C		89	81	74	71	70		85	79	72	70	69	110	80	75	70	68	67
	R.P.M	sopl.		2400	2900	3800	4500	4800		2400	2900	3800	4500	4800	1400	2400	2900	3800	4500	4800
	R.P.M	mtr.		2915	2925	2930	2940	2940		2915	2925	2930	2940	2940	2915	2925	2930	2940	2945	2945
	Kw	N.abs Kw		6,24	7,54	9,88	11,7	12,48		8,8	10,6	13,9	16,5	17,6	7,4	12,7	15,4	20,2	23,9	25,5
	Kw	N.motor		11	15	18,5	22	22		11	15	18,5	22	22	11	15	18,5	22	30	30
	dB(A)	s.cab.		83	84	89	93	94		77	80	86	90	91	75	82	85	90	95	95
dB(A)	c.cab.		73	73	74	75	75		65	67	70	72	72	65	66	68	71	74	74	
800	Q1	m3/min		3,12	4,15	6,01	7,46	8,08		4,46	5,86	8,38	10,34	11,18		7,00	9,07	12,80	15,70	
	Δt	°C		105	95	86	82	81		100	92	84	81	80		94	88	82	79	
	R.P.M	sopl.		2400	2900	3800	4500	4800		2400	2900	3800	4500	4800		2400	2900	3800	4500	
	R.P.M	mtr.		2915	2925	2930	2945	2945		2915	2925	2930	2945	2945		2930	2940	2945	2945	
	Kw	N.abs Kw		7,07	8,54	11,19	13,25	14,13		9,9	12	15,7	18,6	19,8		14,4	17,4	22,8	27	
	Kw	N.motor		11	15	18,5	30	30		11	15	18,5	30	30		18,5	22	30	30	
	dB(A)	s.cab.		83	83	89	94	94		78	81	87	91	91		83	86	92	95	
dB(A)	c.cab.		73	74	74	75	75		65	67	70	72	72		66	68	71	74		
900	Q1	m3/min		4,04	5,9	7,35	7,97			5,73	8,25	10,21	11,05							
	Δt	°C		110	99	94	92			106	96	92	91							
	R.P.M	sopl.		2900	3800	4500	4800			2900	3800	4500	4800							
	R.P.M	mtr.		2925	2930	2945	2945			2925	2930	2945	2945							
	Kw	N.abs Kw		9,54	12,5	14,8	15,79			13,3	17,5	20,7	22,1							
	Kw	N.motor		15	18,5	30	30			15	18,5	30	30							
	dB(A)	s.cab.		91	93	95	96			82	86	92	92							
dB(A)	c.cab.		73	74	75	76			68	70	72	73								
1000	Q1	m3/min		5,8	7,24	7,86				8,12	10,08	10,92								
	Δt	°C		112	106	104				109	104	102								
	R.P.M	sopl.		3800	4500	4800				3800	4500	4800								
	R.P.M	mtr.		2940	2945	2945				2940	2945	2945								
	Kw	N.abs Kw		13,81	16,35	17,44				19,3	22,8	24,3								
	Kw	N.motor		22	30	30				22	30	30								
	dB(A)	s.cab.		94	97	97				87	93	93								
dB(A)	c.cab.		75	76	76				71	73	74									

- Características referidas a: δ=1,2 Kg/m³ (P1=1 bar abs. t1=20°C)  
- Tolerancia de caudal y potencia absorbida: ± 5%  
- Nivel sonoro medio en campo abierto  
a 1m. de distancia Tolerancia: ± 2dB(A)  
- Δt °C = incremento de temperatura

- Performance data refer to: δ=1,2 Kg/m³ (P1=1 bar abs. t1=20°C)  
- Tolerance for inlet flow and absorbed power: ± 5%  
- Noise level refer to out door measurements  
at a distance of 1m. Tolerance: ± 2dB(A)  
- Δt °C = increase of temperature

# Información técnica

## Technical information

# PG 30 - F1

# Consultar cuando se requieran presiones y caudales no contemplados.  
Ask when requested pressures and intake capacities are not shown.

Δp/ mbar	Tamaño / Size	32.10 / DN-100						32.20 / DN-100				DN-150	32.30 / DN-150										
		Q1	m3/min	3,33	6,10	10,06	11,65	15,21	16,40	17,59	5,00	8,92	14,52	16,76	X	22,92	25,16	7,04	12,61	20,57	23,75	30,12	32,51
300	Q1	m3/min	3,33	6,10	10,06	11,65	15,21	16,40	17,59	5,00	8,92	14,52	16,76	X	22,92	25,16	7,04	12,61	20,57	23,75	30,12	32,51	35,69
	Δt	°C	35	31	28	27	27	27	27	34	30	28	27	X	27	26	33	29	27	27	27	26	26
	R.P.M	sopl.	1200	1900	2900	3300	4200	4500	4800	1200	1900	2900	3300	X	4400	4800	1200	1900	2900	3300	4100	4400	4800
	R.P.M	mtr.	1450	2910	2925	2925	2925	2925	2925	1450	2910	2925	2925	X	2940	2940	2910	2915	2925	2930	2945	2945	2945
	Kw	N.abs Kw	2,72	4,31	6,58	8,63	9,53	10,22	10,9	4,3	6,7	10,3	11,7	X	15,6	17	6	9,5	14,4	16,4	20,4	21,9	23,9
	Kw	N.motor	4	5,5	7,5	11	11	15	15	5,5	7,5	15	15		22	22	7,5	11	18,5	22	30	30	3
	dB(A)	s.cab.	87	88	88	88	90	91															





# Información técnica

## Technical information

# PG 30 - F1

Δp/ mbar	Tamaño / Size	35.10 / DN-200						DN-250		35.20 / DN-250							
		16,42	33,42	41,14	53,50	59,68	65,86	68,95	22,23	45,05	55,43	72,03	80,33	88,63	92,70		
300	Q1	m3/min															
	Δt	°C															
	R.P.M	sopl.															
	R.P.M	mtr.															
	Kw	N.abs Kw															
		N.motor															
	dB(A)	s.cab.															
c.cab.																	
400	Q1	m3/min															
	Δt	°C															
	R.P.M	sopl.															
	R.P.M	mtr.															
	Kw	N.abs Kw															
		N.motor															
	dB(A)	s.cab.															
c.cab.																	
500	Q1	m3/min															
	Δt	°C															
	R.P.M	sopl.															
	R.P.M	mtr.															
	Kw	N.abs Kw															
		N.motor															
	dB(A)	s.cab.															
c.cab.																	
600	Q1	m3/min															
	Δt	°C															
	R.P.M	sopl.															
	R.P.M	mtr.															
	Kw	N.abs Kw															
		N.motor															
	dB(A)	s.cab.															
c.cab.																	
700	Q1	m3/min															
	Δt	°C															
	R.P.M	sopl.															
	R.P.M	mtr.															
	Kw	N.abs Kw															
		N.motor															
	dB(A)	s.cab.															
c.cab.																	
800	Q1	m3/min															
	Δt	°C															
	R.P.M	sopl.															
	R.P.M	mtr.															
	Kw	N.abs Kw															
		N.motor															
	dB(A)	s.cab.															
c.cab.																	
900	Q1	m3/min															
	Δt	°C															
	R.P.M	sopl.															
	R.P.M	mtr.															
	Kw	N.abs Kw															
		N.motor															
	dB(A)	s.cab.															
c.cab.																	
1000	Q1	m3/min															
	Δt	°C															
	R.P.M	sopl.															
	R.P.M	mtr.															
	Kw	N.abs Kw															
		N.motor															
	dB(A)	s.cab.															
c.cab.																	

# Información técnica

## Technical information

# PG 30 - F1

Δp/ mbar	Tamaño / Size	36.10 / DN-250						36.20 / DN-300					
		33,96	58,00	64,01	76,03	82,04	100,00	51,89	88,21	97,29	115,45	124,53	151,77
300	Q1	m3/min											
	Δt	°C											
	R.P.M	sopl.											
	R.P.M	mtr.											
	Kw	N.abs Kw											
		N.motor											
	dB(A)	s.cab.											
c.cab.													
400	Q1	m3/min											
	Δt	°C											
	R.P.M	sopl.											
	R.P.M	mtr.											
	Kw	N.abs Kw											
		N.motor											
	dB(A)	s.cab.											
c.cab.													
500	Q1	m3/min											
	Δt	°C											
	R.P.M	sopl.											
	R.P.M	mtr.											
	Kw	N.abs Kw											
		N.motor											
	dB(A)	s.cab.											
c.cab.													
600	Q1	m3/min											
	Δt	°C											
	R.P.M	sopl.											
	R.P.M	mtr.											
	Kw	N.abs Kw											
		N.motor											
	dB(A)	s.cab.											
c.cab.													
700	Q1	m3/min											
	Δt	°C											
	R.P.M	sopl.											
	R.P.M	mtr.											
	Kw	N.abs Kw											
		N.motor											
	dB(A)	s.cab.											
c.cab.													
800	Q1	m3/min											
	Δt	°C											
	R.P.M	sopl.											
	R.P.M	mtr.											
	Kw	N.abs Kw											
		N.motor											
	dB(A)	s.cab.											
c.cab.													
900	Q1	m3/min											
	Δt	°C											
	R.P.M	sopl.											
	R.P.M	mtr.											
	Kw	N.abs Kw											
		N.motor											
	dB(A)	s.cab.											
c.cab.													
1000	Q1	m3/min											
	Δt	°C											
	R.P.M	sopl.											
	R.P.M	mtr.											
	Kw	N.abs Kw											
		N.motor											
	dB(A)	s.cab.											
c.cab.													

- Características referidas a: δ=1,2 Kg/m³ (P1=1 bar abs. t1=20oC)  
 - Tolerancia de caudal y potencia absorbida: ± 5%  
 - Nivel sonoro medio en campo abierto  
 a 1m. de distancia Tolerancia: ± 2dB(A)  
 - Δt °C = incremento de temperatura

- Performance data refer to: δ=1,2 Kg/m³ (P1=1 bar abs. t1=20oC)  
 - Tolerance for inlet flow and absorbed power: ± 5%  
 - Noise level refer to out door measurements  
 at a distance of 1m. Tolerance: ± 2dB(A)  
 - Δt °C = increase of temperature

- Características referidas a: δ=1,2 Kg/m³ (P1=1 bar abs. t1=20oC)  
 - Tolerancia de caudal y potencia absorbida: ± 5%  
 - Nivel sonoro medio en campo abierto  
 a 1m. de distancia Tolerancia: ± 2dB(A)  
 - Δt °C = incremento de temperatura

- Performance data refer to: δ=1,2 Kg/m³ (P1=1 bar abs. t1=20oC)  
 - Tolerance for inlet flow and absorbed power: ± 5%  
 - Noise level refer to out door measurements  
 at a distance of 1m. Tolerance: ± 2dB(A)  
 - Δt °C = increase of temperature



**Montajes e instalaciones**  
*Specials and facilities*

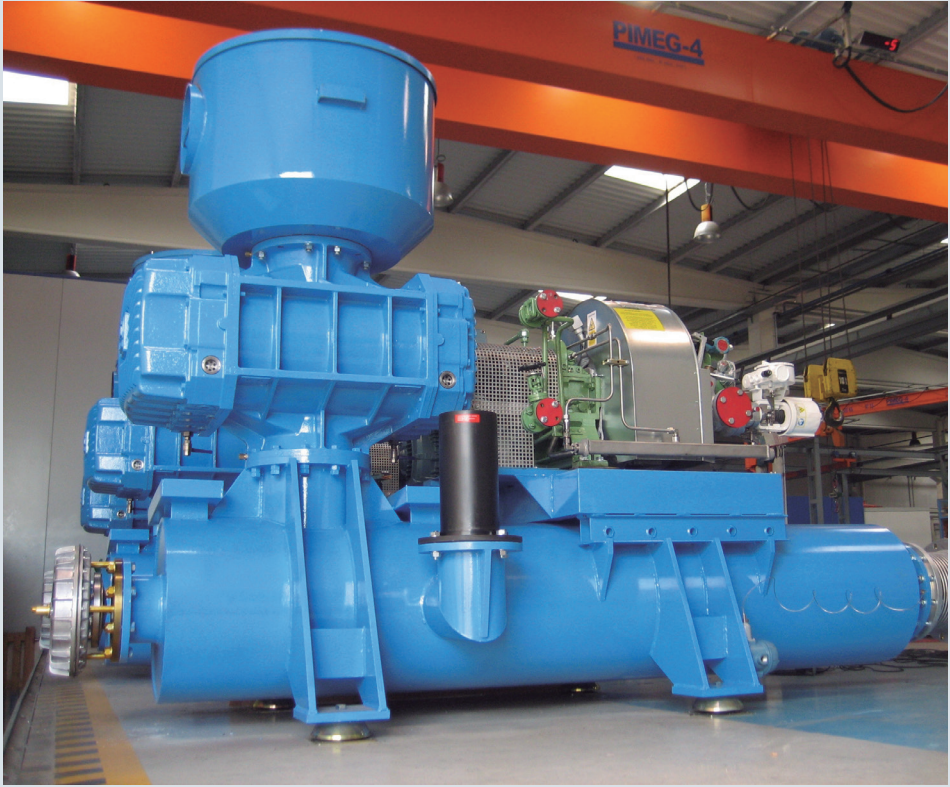
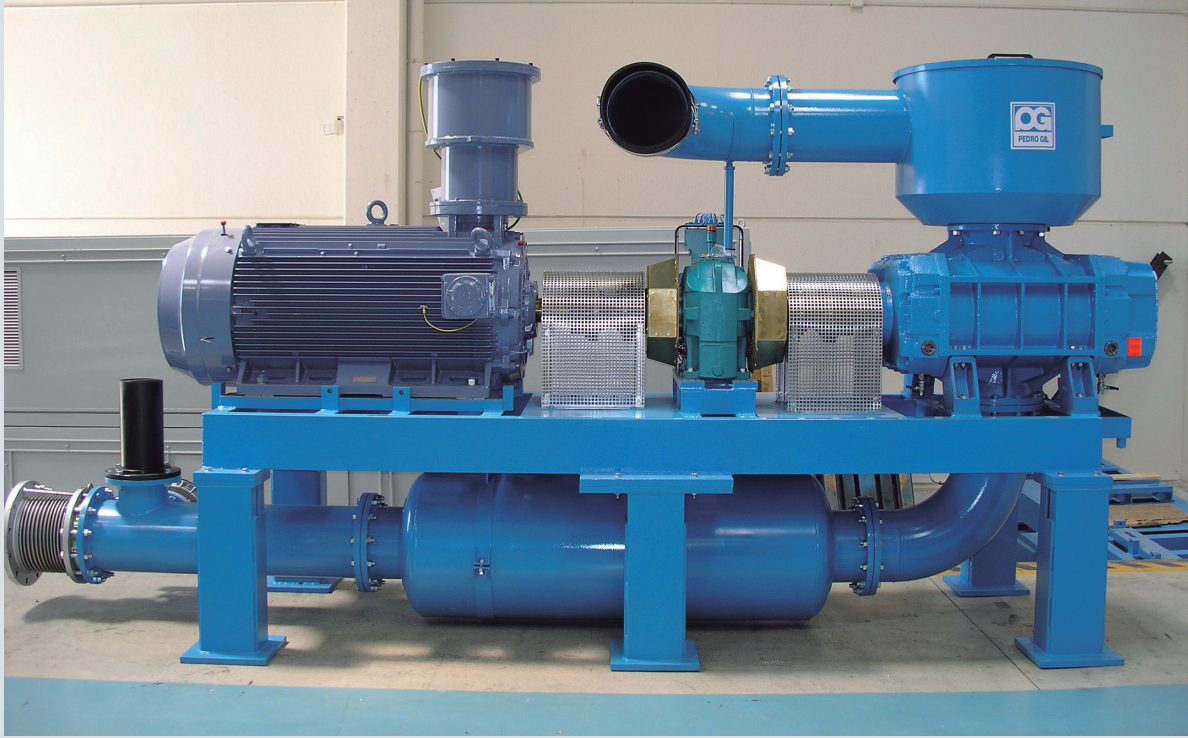





**PEDRO GIL S.L.**

Salvador Albert i Riera, 9 · Pol. Ind. Vallmorena · 08339 Vilassar de Dalt · Barcelona · España  
Tel: +34 93 753 71 71 · Fax: +34 93 753 73 00 · E-mail: [ventas@pedrogil.com](mailto:ventas@pedrogil.com) · [www.pedrogil.com](http://www.pedrogil.com)