

# Satron VOM

Turbidity and solids sensor for  
Food and Biopharma

The SATRON VO sensor allows savings to be obtained in process industries such as:

- Transition monitoring for startup, changeovers and shut-down
- CIP return line monitoring
- Automation of yeast harvesting in breweries
- Integrity monitoring of filters

The sensor uses fully flat front process side flushing and communicates via 4...20mA and digitally using the HART® protocol.



## TECHNICAL SPECIFICATIONS

### Measuring range

0 ... 300 000NTU equivalent

### Calibration

The sensor is factory calibrated at 4mA = water, 20mA = 2% fat cow milk, freely adjustable with pushbuttons or Hart® modem.

### Damping

Time constant adjustable 0.01 to 60 s.

### Repeatability

0.1% from maximum span.

### Response time

0.1s (with less than 0.1s damping)

### Accuracy

0...1 000 NTU	0.25% ±50 NTU offset
1 000....10 000 NTU	1%
10 000...300 000 NTU	5%

### Unit selection

%, NTU, FNU, FTU, mg/L, g/dm<sup>3</sup>, PPM

### Temperature limits

Ambient: -30 to +80 °C (-22 ...176°F)  
 Process N type: -5 to +100 °C (23 ...212 °F)  
 (120 °C for 10 min) (248 °F)  
 Process H type: -5 to +140 °C (23 ...284 °F)  
 (160 °C for 30 min) (320 °F)  
 Shipping & storage: -40 to +80 °C  
 (-40 ...176 °F)  
 Display operating range: 0 to +50 °C  
 (Does not affect operation of the sensor)

**Output** 3-wire (3W), 4-20 mA NAMUR NE43

### Supply voltage

Nominal 24 VDC, (21.6 - 27.6V) 200mA

**Humidity limits** 0-100% RH

### Pressure class:

- PN40  
 - Test pressure -1 to 250 bar (-14.5 to 3625.94 PSI)

### EMC directive 2014/30/EC

- EN 61326-1: 2013

### CONSTRUCTION

#### Materials:

Sensing element <sup>1)</sup>: AISI316L, PEEK, Duplex (EN. 1.4462), Hast. C276/C22, or Titanium Gr2.  
 Surface quality: Polished Ra <0.8µm  
 Lens: Sapphire or Spinel ceramic

#### Housing with display, code N:

Housing: AISI303/316  
 Seals: Nitrilerubber and Viton®  
 Nameplates: Polyester

#### Housing without display, code H:

Housing: AISI303/316  
 Seals: Viton® and NBR  
 Nameplates: Polyester

#### Connection hose between sensing element and housing (RDU) code L:

PVC signal cable or hose protected with PTFE/AISI316 braiding  
 Nameplates: Polyester

### Electrical connections

Housing without display code H:  
 1x M12 plug connector  
 Housing with display, code N:  
 2x M12 plug connector

### I/O-connections

Current output1	Turbidity active
Range (Namur NE 043)	3.5...23 mA
Maximum load	600 Ω
Factory setting	4...20 mA

#### Switch outputs (up to 3 available)

solid state relay, grounding contact  
 Maximum voltage 35 V  
 Maximum current 50 mA  
 Maximum leakage current 10 µA

#### Switch inputs (up to 3 available)

NC (no connection)	OFF
0...2 V	ON
Minimum values for switch in use	
Voltage	16 V
Current	4 mA
Leakage current	1 mA

Current output2  
 Internal power supply

Current output 2 has same ground as binary IO

Maximum load	400 Ω
Range	3.5...23 mA
Factory setting	4...20 mA
External power supply	
Current output 2 is galvanically isolated	

Maximum supply voltage	35 VDC
Range	3.5...23 mA
Factory setting	4...20 mA
Maximum isolation voltage	100 VDC

### Process connections

- With G1 connecting thread
- Tri-Clamp 25/38 and 40/51
- Tuchenhangen Type "N"
- 1" retractable "B1"

**Protection class:** IP66, IP67 and IP68  
 See Selection chart.

### Weight

Housing without (H):	0.9 kg
Housing with Display (N):	1.3 kg
Remote Housing (L):	2.5 kg
Remote sensor (R):	2.5 kg

Output signal according to NAMUR NE043 Signal Level for the failure information of Digital Transmitters.

Min. load using HART®-communication 250 Ω

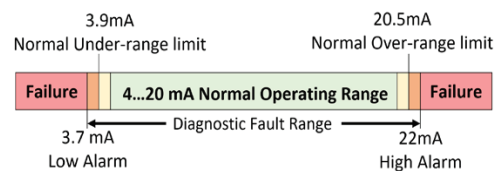

**UL 61010-1, 3rd Ed. Rev May 11, 2012**  
**CAN/CSA C22.2 No. 61010-1-12, Ed. 3**  
**EMC directive 2014/30/EC**

- EN 61326-1:2013

<sup>1)</sup> Parts in contact with process medium compliant to FDA

**Dimensions and Housing types VOM (mm)**

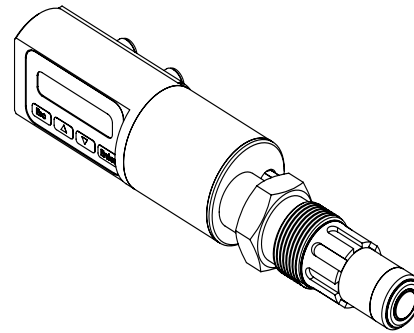
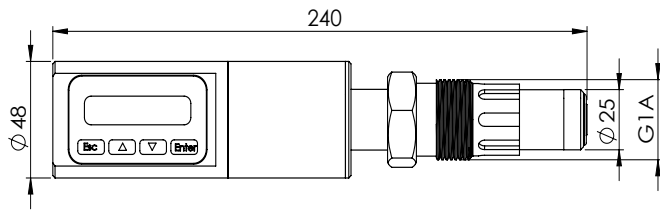

**VOM with display (N) and G1 process connection**

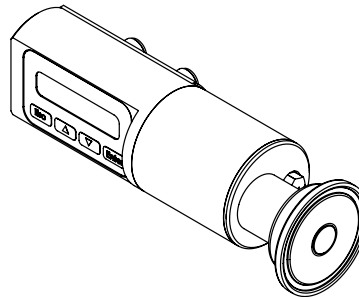
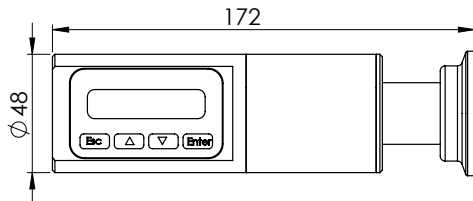

**VOM with display (N) and Tx clamp connection**

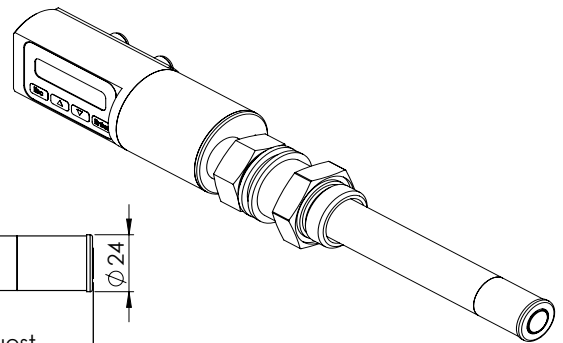
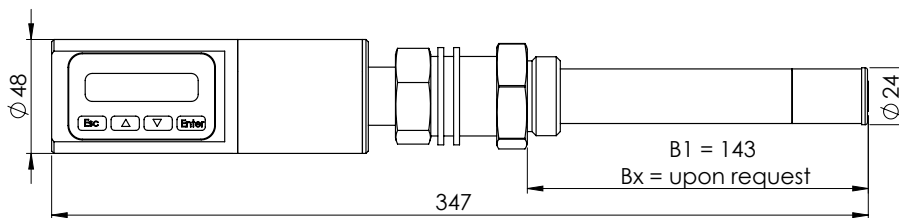

**VOM with display (N) and B1 / BX ball valve insertion process connection**

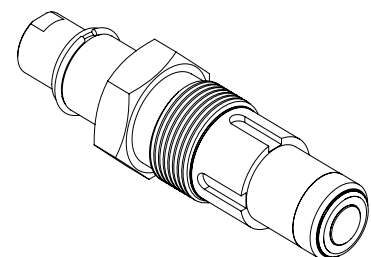
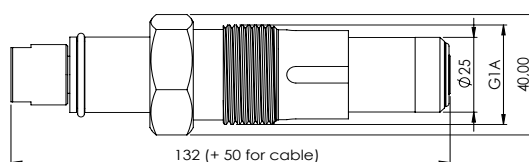
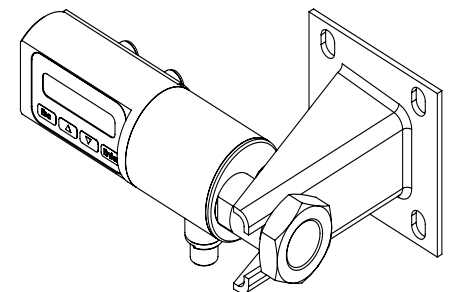
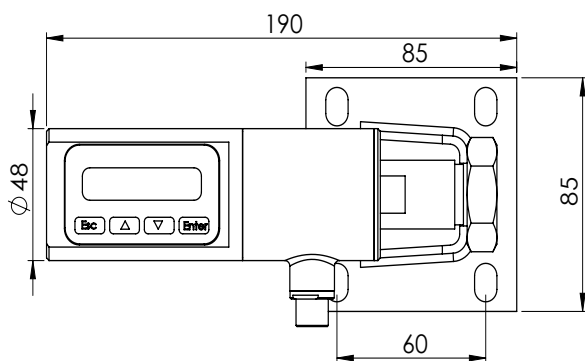

**VOM with remote measuring probe and PVC M12 cable (NRT43)**

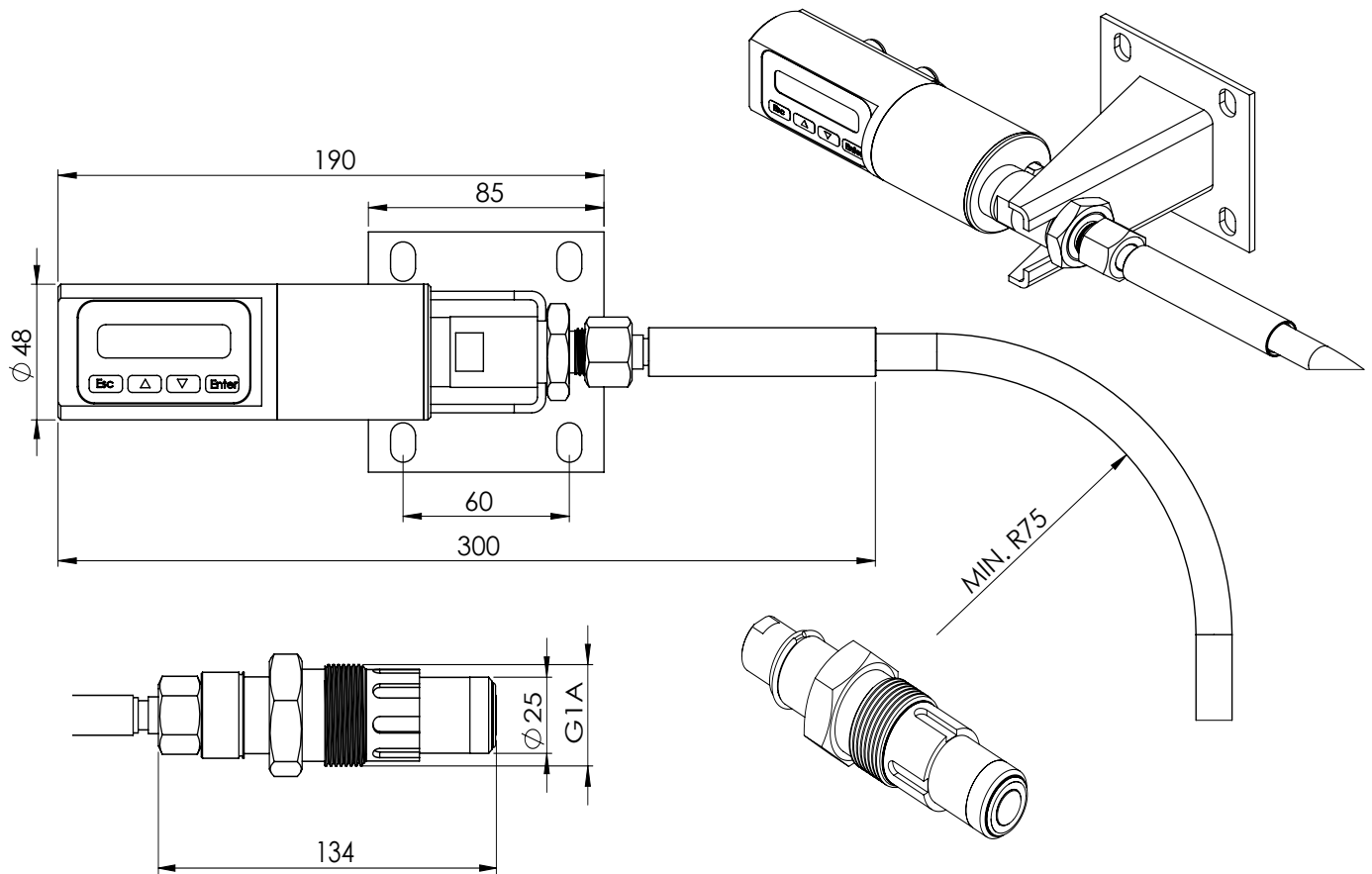

**VOM with remote measuring probe and AISI or PUR hose (NRT2)**

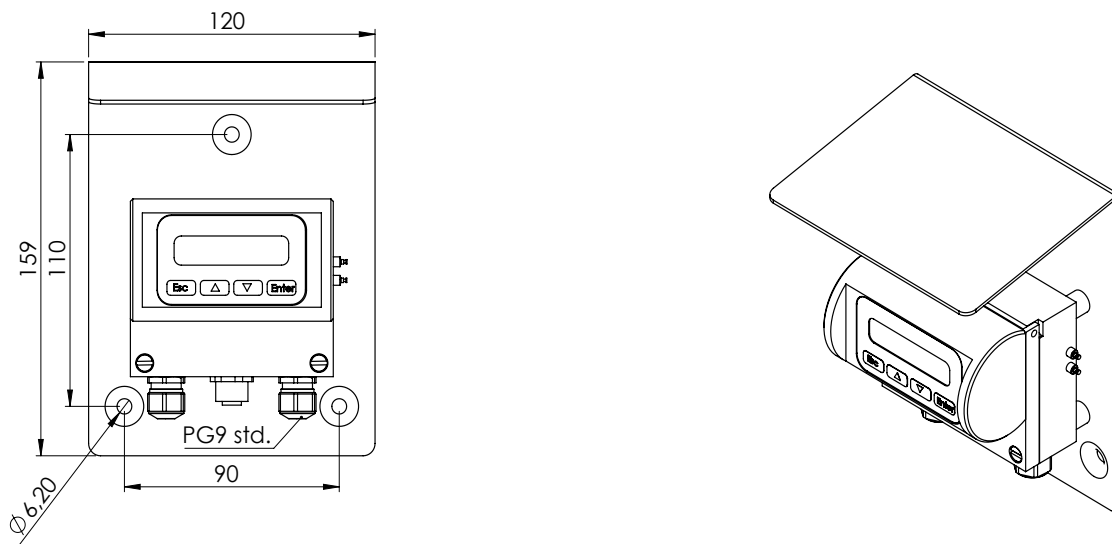

**RDU - Remote Display Unit (L) T1325016**

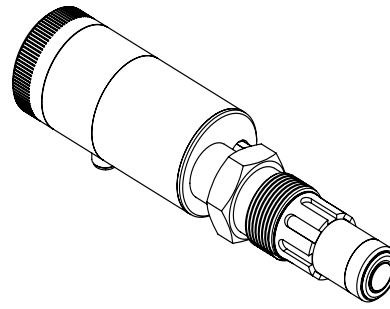
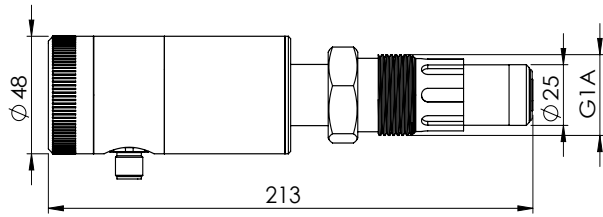

**VOM without display (H) and G1 process connection**

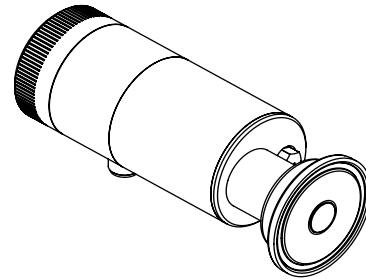
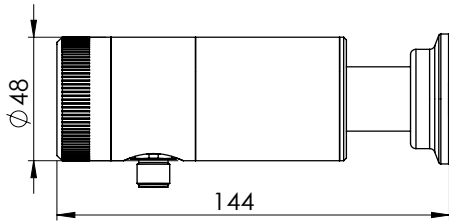

**VOM without display (H) and TA, TB and TN clamp connection**

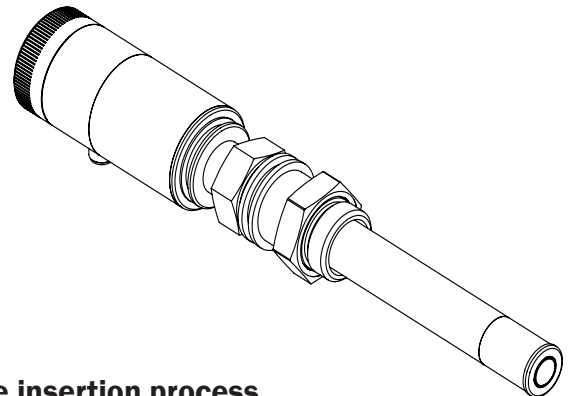
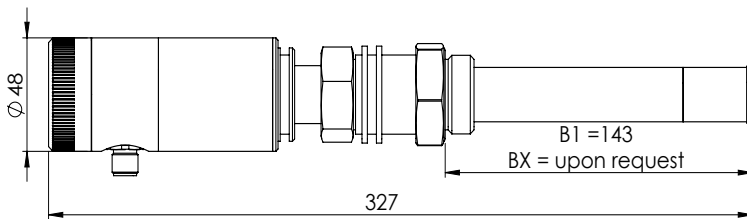

**VOM without display (H) and B1 / BX retractable ball valve insertion process**

**Process connection details**

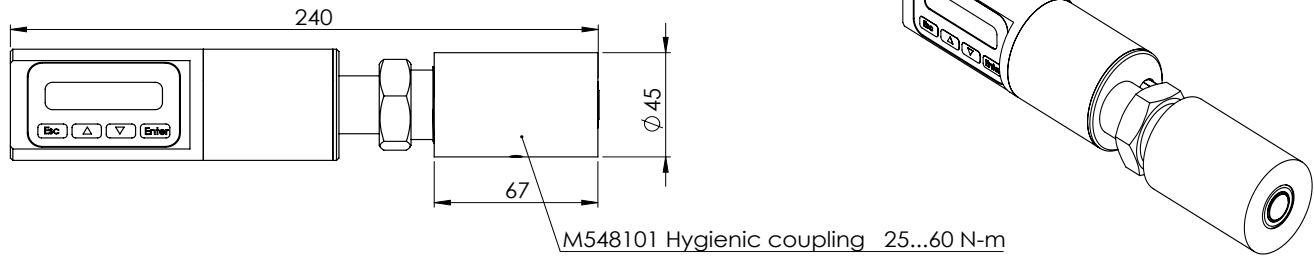

**VOM G1 connected to M548101 hygienic coupling. (Flush mounted) EHEDG, 3A**

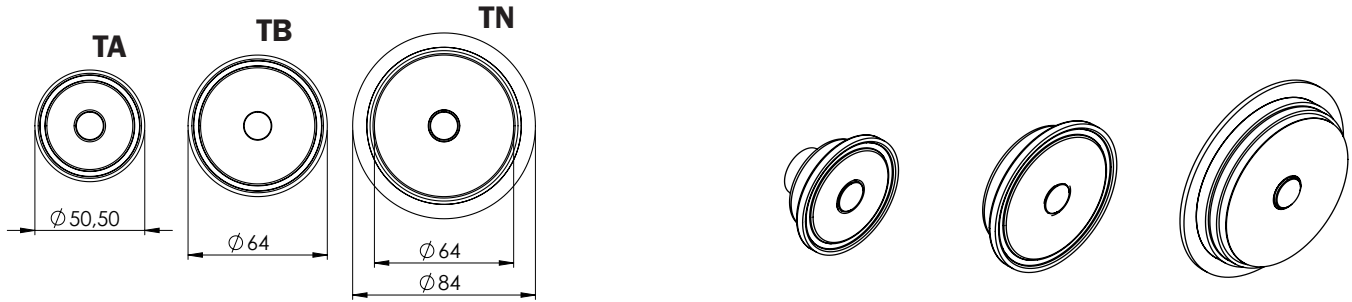

**VOM with Tri-clover TA, TB (ISO 2852) and Tuchenhagen TN process connection**

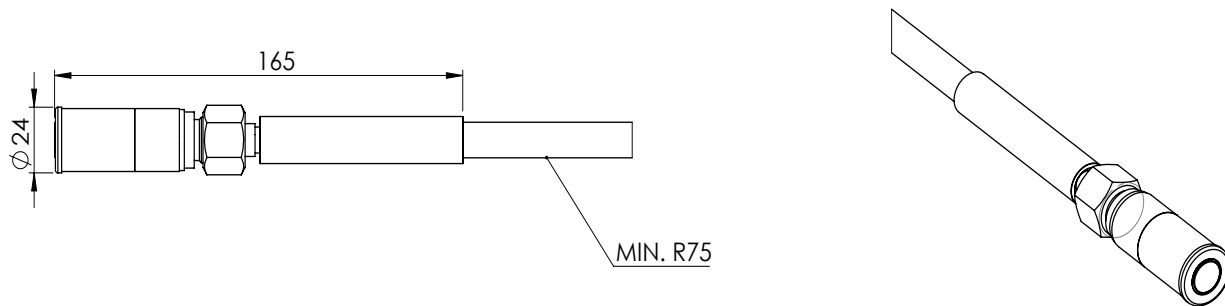

**VOM with H1 fixed mounting tube process connection and AISI316L hose, "21.H1"**

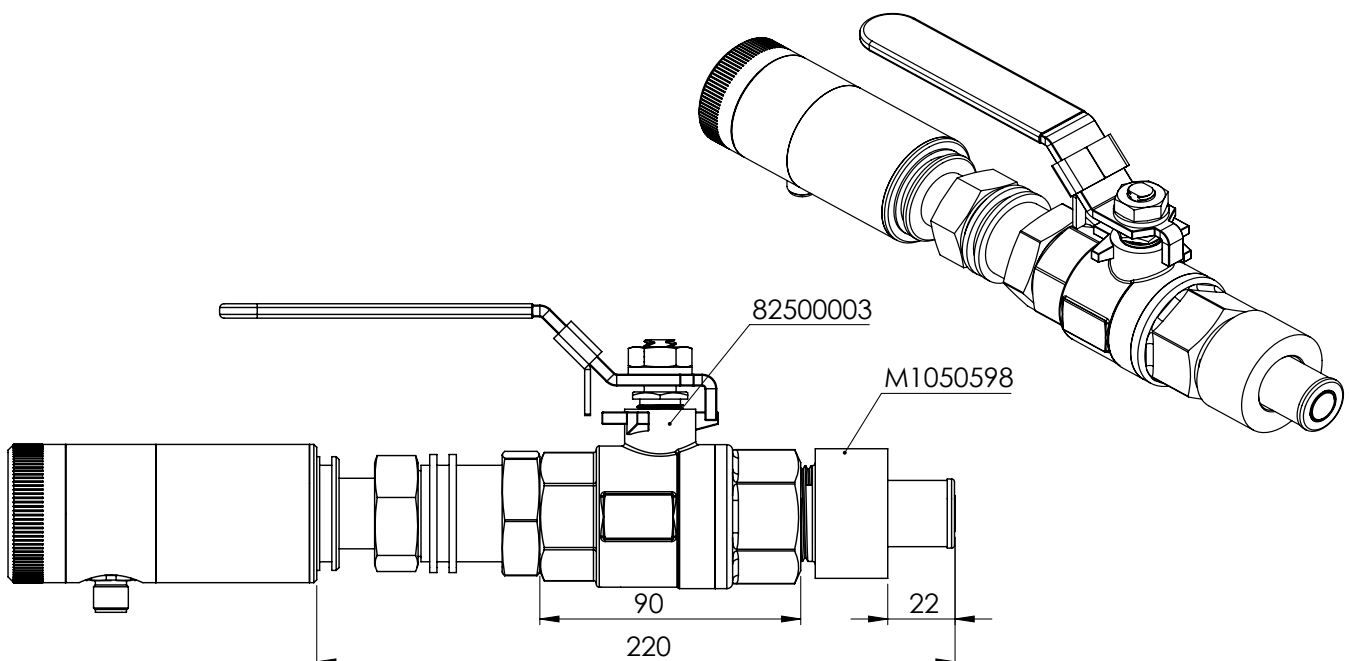

**VOM B1 connected to Ball valve 82500003 and M1050598 coupling**

## Instructions and spare parts that are according and within the 3-A appliance



### Welding the coupling

These instructions apply to hygienic welded couplings; welding the G1 standard coupling is described here as an example.

- Place the coupling in the mounting hole. Make sure the leakage detection port is down. Then weld with several runs so to prevent the coupling's oval distortion and tightness problems. The inside welding must be cleaned, and polished with an end result of Ra <0,8
- The sensor must be **out of the coupling** while the coupling is welded. You can use the shut-off plug to shut the coupling. The plug protects the coupling's sealing face and permits the starting of the process without the sensor.
- It is always recommendable to use the welding assistant (M1050420) while welding the coupling to prevent any distortions due to heat.
- Do not make weld grounding via any sensor's body!

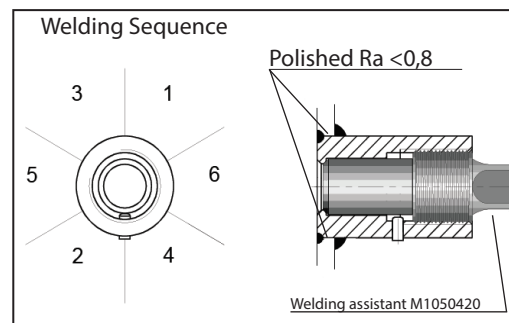

### Mounting the sensor on the coupling

#### Procedure

- Make sure that the coupling's sealing face is clean.
- Remove the orange protective plug from the sensor head.
- Insert the sensor **in a straight line** into the coupling, so that the guide groove on the sensor aligns with the stop pin on the coupling. The sensor settles into position when the groove and pin are aligned, and will be prevented from rotating in the coupling.

**When inserting the sensor, be careful not to damage the edge of the lens on the edges of the coupling or on the end of the stop pin!**

- Lock the sensor in position by screwing the hex nut fully home. Finger tightness is sufficient to tighten the sealing faces. However, we recommend final tightening with a tool to eliminate the effect of vibration and other such factors. Apply 60±20 Nm torque.

**Do not use sealing tape etc. on threaded connection!**

### VOM measurement principle:

Backscattering with selectable wavelength lightsource LED (see selection chart)

The light source is fully compensated for aging, temperature, and ambient light changes due to the high duty cycle measurement (up to 100 measurements per second).

The lifetime for the optical LED and photodetectors is 20 years minimum.

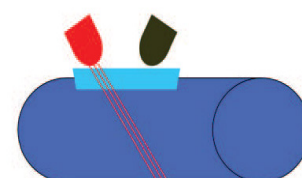
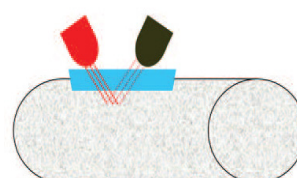
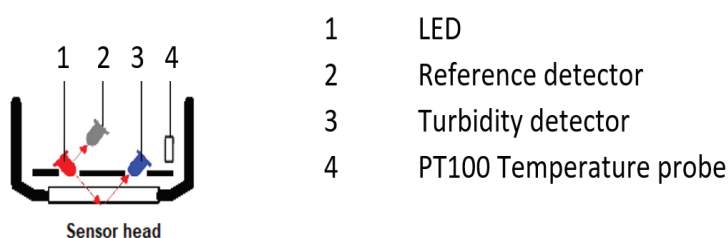

## Spare-parts VOM G1

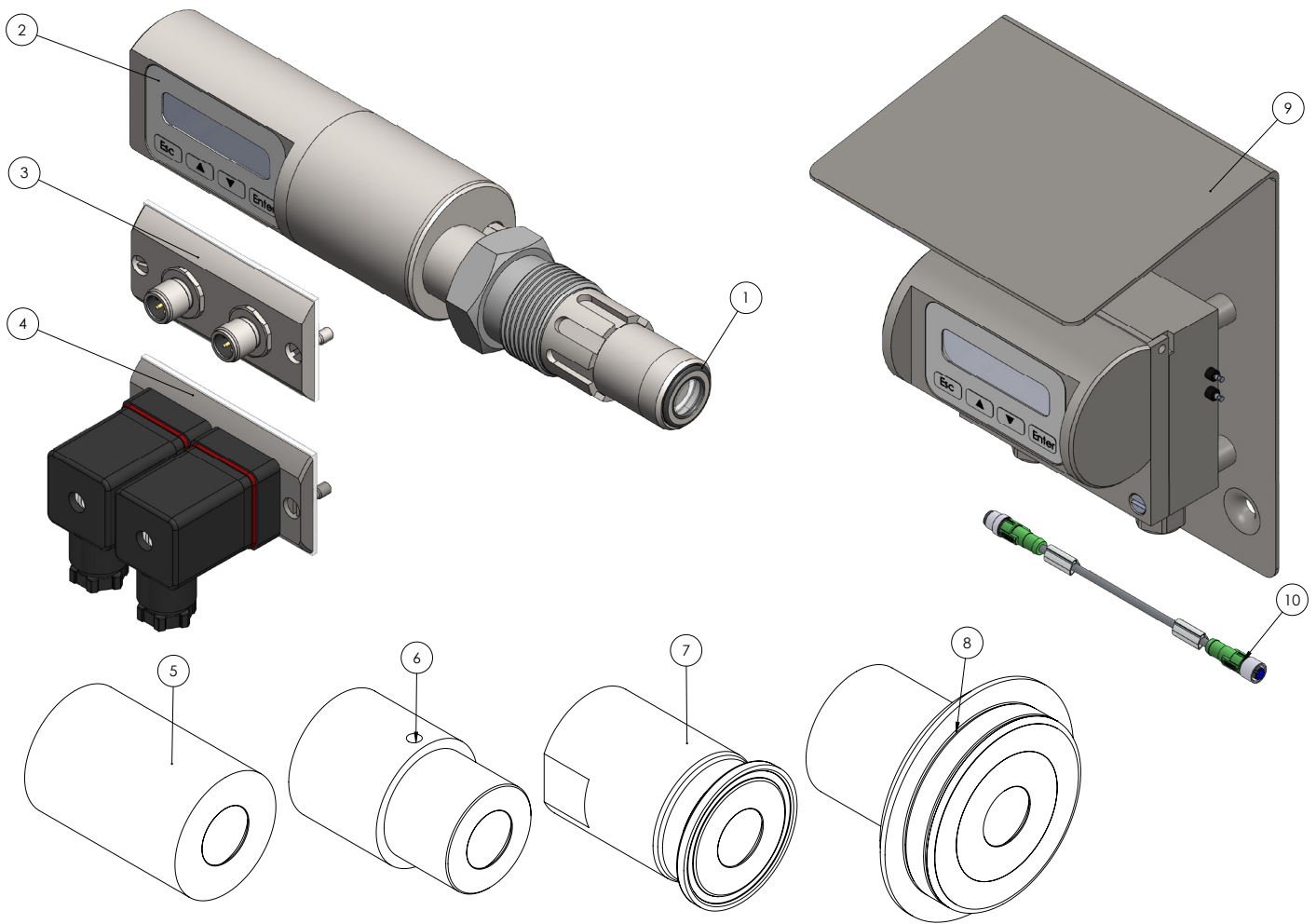

No.	Part name	Order code
1	O-ring EPDM	80031720
1	O-ring FPM (Viton®)	80011720
1	O-ring FFPM(Kalrez®)	80041717
2	Sticker	T1325215
3	Plug cover M12	T1325031
4	Plug cover DIN43650 (old type)	T1325003-K48
5	45/G1" Welding adapter	M548101
6	38/G1" Welding adapter	M1050577
7	Tri-clover 25/38 ISO2852	M1050206
7	Tri-clover 40/51 ISO2852	M1050222
7	Tri-clover 63.5 ISO2852	M1050224
8	Tuchenhagen / Varivent DN25	M1050090
8	Tuchenhagen / Varivent DN50	M1050091
8	Tuchenhagen / Varivent DN65,5	M1050092
9	Remote Display Unit RDU	T13250016
10	L-Housing data cable 10m PVC	70000450
10	L-Housing data cable 15m PVC	70000451
10	Extension cable +10m PVC	70000460
	FUSE for L-Housing	74212000
	Seal for L-Housing display	80017226
	Bracket remote probe electronics	T1050009

### Note

3A 18-03 Class II (Do not exceed above 8% fat content).  
3A 18-03 Class I  
3A 18-03 Class I

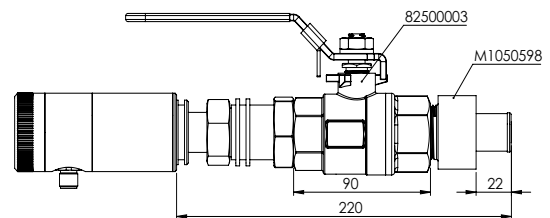

Ballvalve	82500003
Straight coupling for ballvalve	M1050598
15 degree coupling for ballvalve	M1050597



## Selection Chart

<b>Adjustability</b> VOM	<b>Span, min</b> 0... 1000 NTU	<b>Span, max</b> 0... 300 000 NTU		
<b>Process temperature limits</b>	<b>N</b> Normal version -5...+100 °C (23 ...212°F) (120 °C (248°F) for 10 minutos)	<b>H<sup>(**)</sup></b> High temperature -5...+140 °C (23 ...284°F) (160 °C (320°F) for 30 minutos)		
<b>Output</b>	<b>S</b> 4-20mA DC/HART® for 50Hz (Europe)	<b>J</b> 4-20mA DC/HART® for 60Hz (USA / Japan)		
<b>Material of wetted parts</b>	<b>Body</b>	<b>Lens</b>	<b>Seal</b>	<b>3A 18-03</b>
	<b>2</b> AISI316L	<b>2</b> Sapphire	<b>1<sup>(***)</sup></b> EPDM	Class II
	<b>3<sup>(****)</sup></b> Hast. C 276	<b>4</b> Spinel	<b>2</b> FPM (Viton®)	Class I
	<b>6<sup>(****)</sup></b> Titanium Gr2		<b>3</b> FPM (Kalrez®)	Class I
	<b>8<sup>(****)</sup></b> Duplex (EN 1.4462)		<b>4<sup>(*)</sup></b> PTFE (Teflon)	
	<b>9<sup>(****)</sup></b> Peek			
<b>Housing type</b>	<b>B</b> Housing with display and pushbuttons, 1mA output			
	<b>N</b> Housing with display and pushbuttons, 2mA outputs, 3 bin in/outputs			
	<b>H</b> Housing without display			
	<b>L</b> Remote electronics housing with display			
<b>Probe type</b>	<b>0</b> No remote probe			
	<b>R</b> Remote measuring probe (not available with L housing), IP68			
<b>Connection type</b>	<b>T</b> M12, IP67			
	<b>V</b> PG9 (always with L housing), IP66			
<b>Cable Material</b>	<b>0</b> No L or R option selected			
	<b>2<sup>(*)</sup></b> AISI316L braided PTFE hose			
	<b>4</b> PVC cable (std.)			
<b>Cable length</b>	<b>0</b> No L or R option selected			
	<b>2</b> 10 M PVC		<b>3</b> 15 M PVC	
	Extension 10M PVC cable available			
<b>Light source</b>	<b>6</b> 640nm		<b>7</b> 880nm	
<b>Process connections</b>	<b>G1</b> Standard G1A thread + Oring			
	<b>TA</b> Tri-Clover 25/38 (ISO 2852)			
	<b>TB</b> Tri-Clover 40/51 (ISO 2852)			
	<b>TN</b> Tuchenhausen "N" type DN50			
	<b>H1<sup>(*)</sup></b> Fixed mounting tube (see H1 picture)			
	<b>HX<sup>(*)</sup></b> Fixed mounting tube (specify length)			
	<b>B1<sup>(*)</sup></b> G1A ball valve insertion. Extension 19cm diameter ø 24mm			
	<b>BX<sup>(*)</sup></b> G1A ball valve insertion. Extension on request			

### Documentation

**Calibration certificate** **AE** English

**Installation and operating instructions** **IE** English **IF** Finnish **FR** French

### Material certificates

**0** No material certificate

**MC1** Raw material certificate without appendices, in accordance with SFS-EN 10204-2.1 (DIN 50049-2.1) standard

**MC2** Raw material certificate for wetted parts, in accordance with SFS-EN 10204-2.2 (DIN 50049-2.2) standard

**MC3** Raw material certificate for wetted parts, in accordance with SFS-EN 10204-3.1 B (DIN 50049-3.1 B) standard

\* Not EHEDG certified & Not within the 3A approval  
 \*\* For EHEDG & 3A in combination with Kalrez Seals  
 \*\*\* Do not exceed above 8% fat content process media  
 \*\*\*\* Only process connection G1



UL 61010-1, 3rd Ed. Rev May 11. 2012  
 CAN/CSA C22.2 No. 61010-1-12, Ed. 3  
 EMC directive 2014/30/EC  
 - EN 61326-1:2013  
 1) Parts in contact with process medium compliant to FDA

We reserve the right for technical modifications without prior notice.

HART is the registered trademark of HART Communication Foundation.  
 PASVE is the registered trademark of Satron Instruments Inc.  
 Hastelloy is the registered trademark of Haynes International.  
 Viton is the registered trademark of DuPont Down Elastomer.  
 3-A is a registered mark owned and administered by 3-A SSI.