

Intermittent Bagmaker S250



Our rugged S250 vertical bagger delivers exceptional speed and repeatability through a quiet, servo driven jaw. This vertical bagmaker is perfect for packaging snacks, candy, coffee, fresh and frozen fruit, and more.

max.
speed

150
bpm

bag
size

max.
250 mm x 400 mm (9.84" x 15.75")
min.
50 mm x 60 mm (2" x 2.38")

Bag Types

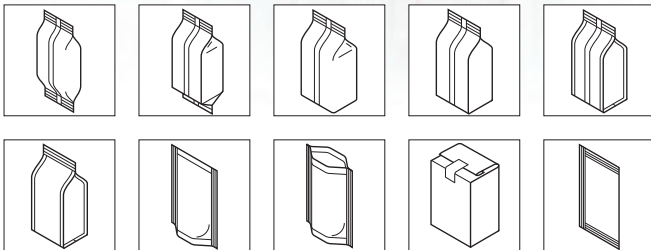

Bag Options

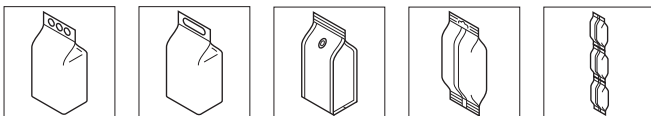

Recloseable Solutions



Intermittent Bagmaker S250 In Detail

What's better than a highly reliable bagger with a repeatable delivery? One that's also incredibly fast. Meet the S250 (S300), an impressive vertical form, fill and seal machine that provides the stainless steel sanitary design and affordability you've come to expect from our S Series. Want efficiency? With speeds up to 150 bags per minute, faster, repeatable and accurate production runs will be the norm. Want consistency? The S250 prevents bottlenecks. Want flexibility? The S250 accommodates several bag styles, including quad-seal. Want peace of mind? Make the S250 your next investment.

features

- › Robust, stainless steel frame
- › Siemens or Allen Bradley control system
- › Servo-drive jaw actuation
- › Open frame design
- › Off-the-shelf components
- › Minimal maintenance requirements
- › Short film path
- › Small machine footprint
- › No tool changeover
- › Self-centering pull belts
- › Automatic film tracking
- › VFD powered film unwind
- › Quick film splice table
- › Photo eye and encoder
- › Automatic machine stop
- › Jaw obstruction detection
- › Runs most film structures
- › Storage for 100 product recipes

options

- › Upgrade 300 mm bag width
- › Continuous motion mode
- › Ultrasonic sealing jaws
- › Quad seal bag assembly
- › Servo pull belts actuation
- › Flat bottom bag assembly
- › Impulse sealing for poly film structures
- › Washdown IP66 construction
- › Vacuum pull belts
- › Fold-down/tape-down unit
- › Hole punch (Euroslot and Round)
- › Load shelf
- › Product settler
- › Gas flush
- › Static elimination
- › Tear notch
- › Product staggers
- › End-seal cooling air
- › Bag deflators
- › Degassing valve applicator
- › Remote diagnostics
- › Zipper applicator
- › Bag-in-bag configuration
- › Integration with variety of fillers, printers, metal detectors, label applicators, and checkweighers
- › In-feed and take-away conveyors

Machine drawings

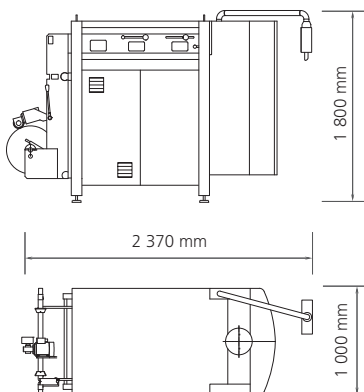

Max. speed

150 bpm

Weight

950 kg (2,095 lbs)

Bag width

50–300 mm
(2"–11.8")

Air pressure

6 bar
(15–18 CFM at 90 PSI)

Bag length

60–400 mm
(2.38"–15.75")

Power supply

7.9 kVA
(480 V, three phase,
60 Hz., 20 AMPS)

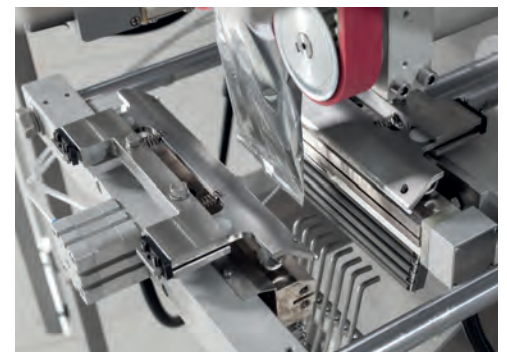

Europe, Asia, Africa, Australia

Viking Mašek, a.s. | Průmyslová 1747 | 258 01 Vlašim | Czech Republic

Phone +420 317 850 500 | **Email** info@masek.cz | **Website** www.masek.cz, www.vikingmasek.cz

North and South America

Viking Masek Global Packaging Technologies, Inc. | 40 Woodland Court | Oostburg, WI 53070 | USA

Phone +1 920 564 5051 | **Email** sales@vikingmasek.com | **Website** www.vikingmasek.com