

# **WILK-GRAPHITE** **EQUIPMENT FOR THE CPI**

GRAPHITE HEAT EXCHANGER AND COMPONENTS FOR  
CORROSIVE APPLICATIONS

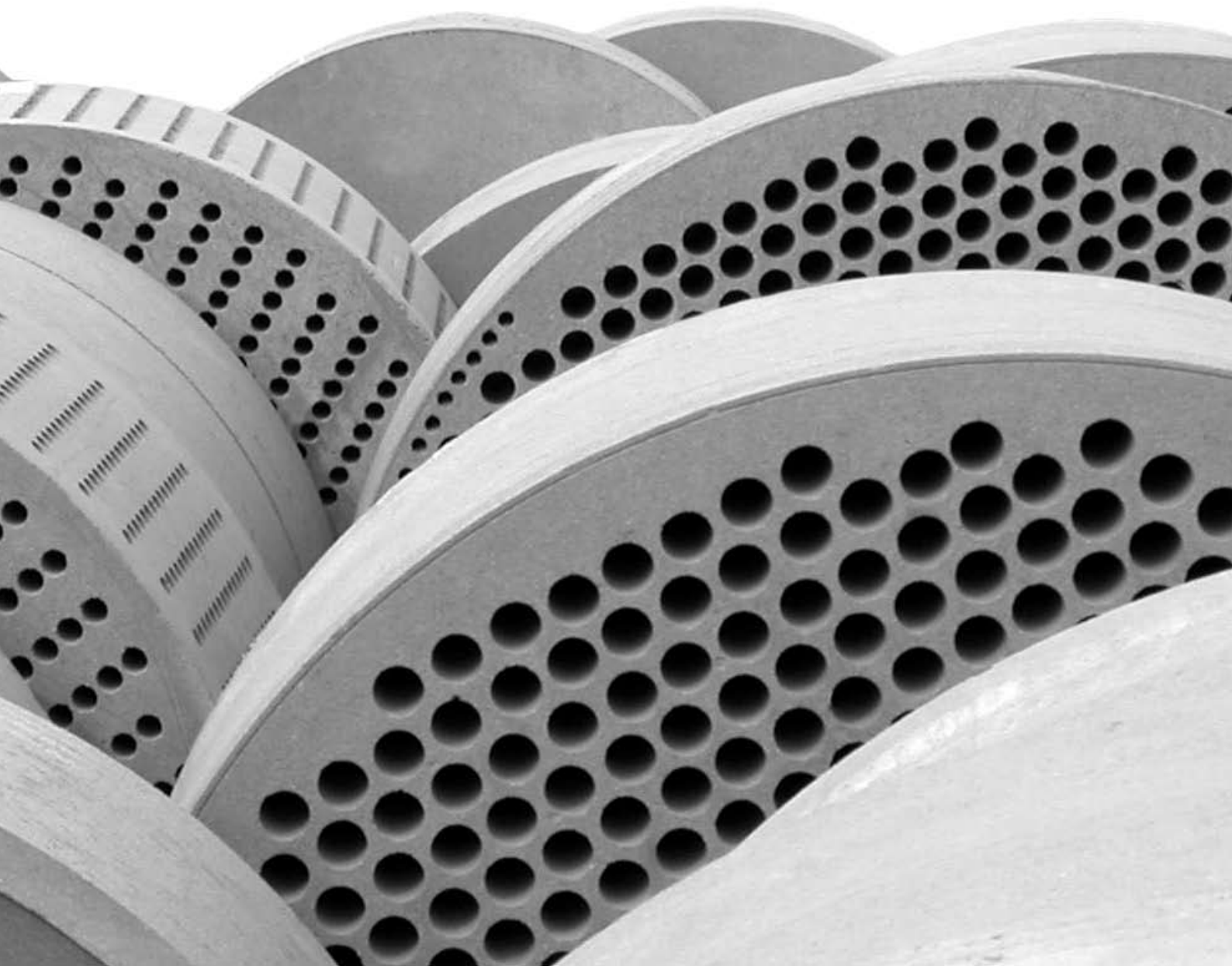

## Wilk - Graphite

**W**ilk - Graphite stands for first class graphite equipment from one of the largest producers worldwide. All the products offered exclusively to the international markets represent the state of the art of graphite manufacturing and look back on long reference lists with thousands of units installed in various chemical surroundings. Every piece of equipment installed shows an excellent, competitive life time even in severe applications.

Wilk-Graphite provides technical service, an international network and the ability to serve our clients with high quality products.

Wilk-Graphite has been founded 2005 by Andreas Wilk, who has been in the field of corrosion protection and for many years. It is our goal to support the international competitiveness of our customers with economical interesting pricing for lower investment and maintenance cost. Co Owners of Wilk-graphite are Mr. Feng as the owner of Nantong Sunshine and Ansgar Hachenberg

### **Nantong Sunshine Graphite Equipment Technology Co. Ltd**

The equipment is produced by the privately owned, independent company Nantong Sunshine Graphite Equipment Technology Co. Ltd, who is Chinas market leader. Since 1995 graphite equipment like heat exchangers are manufactured and sold first mainly to local companies, then to Joint ventures and finally also to foreign companies. In addition to the production of high quality equipment Sunshine developed its own engineering department, mainly focusing on acid recovery processes and HCL synthesis units.



The leading position in the market made Sunshine the preferred supplier being familiar with the needs of the chemical industry.

Raw graphite supply and development is secured by own independent sources.

### **Tectrion**

Our professional service is performed by Tectrion, who were newly founded as the follow up company of Bayer Industry Service. Many years of experience in the field of graphite equipment maintenance for the Bayer AG, a large number of skilled technicians and a fully equipped workshop make Tectrion the preferred partner for Wilk-Graphite. Both parties agrees on a long term partnership. Also the storage of Wilk-Graphite is located in Leverkusen.

A 24 hour service at our customers side is secured.

### **Guarantee**

Guarantees on the mechanical performance and if asked for, the thermodynamic design are included and follow the European standards.

### **References**

The heat exchangers and all other units are installed in many different applications for years with excellent results. More than 5000 references are available. Please ask for a reference for your process.

### **Nantong Sunshine Graphite Technology**

- more than 350 Employees
- production capacity of 50.000 m<sup>2</sup>/a
- privately owned since 1995
- more than 5000 units installed
- all design and development in-house

### **Service**

Wilk-Graphite offers full service from general technical support, thermodynamic lay out to a after sales service. In an emergency case we are set up to provide fast service.

- Service point in Germany
- Fast delivery of spare parts ex stock from Germany or by air from China
- Local support by experienced representatives
- Fast delivery from China within only a few days in case of an emergency

### **ISO - Certificate**

Nantong Sunshine has been certified according to ISO 9001:2000 by European Bureau Veritas and is subject to routine audit.

### **International Standards**

All products are designed and manufactured according to international standards like the European Pressure Code. The units are tested by independent authorities like the TÜV in China. The nozzle connections may follow ASME or DIN measurements. Please ask for additional norms.



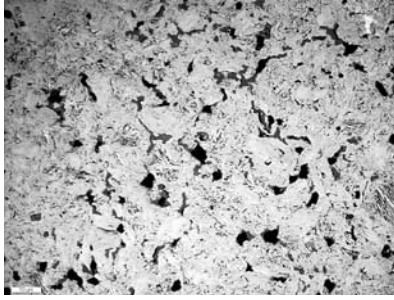

CARBEX BF3 - 200 times larger

## Graphit

Graphite has been established in the past as a well known, reliable material for the Chemical Process Industry. Using various impregnation materials as phenolic resins or PTFE dispersions graphite offers an excellent chemical resistance. With the high thermal conductivity the material became the first choice not only for heat exchanger, which today are available in different designs for many applications, but also for many other equipments used in the CPI. Please see the table on the left for the physical properties.

Graphite made in China by Nantong Sunshine has a particle size of only 0,2 or 0,8 mm and a low surface roughness. The result is an excellent mechanical strength and thermodynamical performance. Following the international standard the units made by Sunshine can replace existing systems one by one.

Beside the high quality graphite also graphite with a particle size of 2 - 3 mm is available, which suits many applications.

Graphite has been successfully installed in all those applications where other material fail because of limited chemical resistance or the price of graphite was very favourable. The materials replaced are exotic alloys like tantalum or hastelloy, glass as a very fractal material and other materials like ceramics.

In the years 2005 to 2009 numerous long term test regarding the mechanical performance or chemical resistance have been executed by our customers or independent research laboratories. Please ask for your copy.



Properties
max. Partice size
density
compressive strength
tensile strength
bending strength
thermal conductivity
lin. coeff. for thermal exp.
allowable temperature
bursting strength (hydr. )
ash content



CARBEX BF3 - 500 times larger

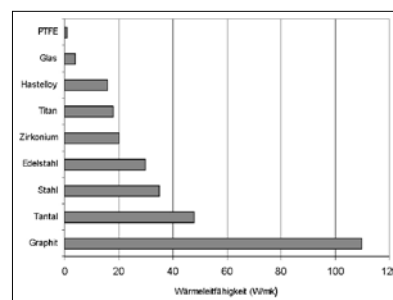

## Impregnation

- Phenolic resin
- Furan resin
- PTFE

## Application

We look back on more than 5000 references and a corrosion table including many different chemicals, temperatures and mixtures. If we do not have information about the chemical resistance of your media, we use our laboratory to test.

## Pipe Materials

Carbex® pipes are available in different kinds for different applications. The variety of the pipes enables us to choose the best pipe for each of our customers application.

- Carbex® T extruded from a mixture of Graphite and Phenolic resin
- Carbex® TB extruded, calcinated and impregnated
- Carbex® TS extruded, graphitized and impregnated
- All pipes can have an optional fiber support to increase the bursting pressure

	Blocks			Pipes			
	Carbex®	Carbex®	Carbex®	Carbex®	Carbex®	Carbex®	Carbex®
unit	BF1	BF2	BF3	T	TT	TB	TS
mm	3	0,8	< 0,2	0,4	0,4	0,4	0,4
kg/cm <sup>3</sup>	1,85 - 1,90	1,89 - 1,92	1,97 - 1,98	> 1,9	> 1,92	> 1,92	> 1,90
Mpa	65 - 74	82 - 91	93 - 94	> 80	> 85	> 80	> 80
Mpa	15 - 18	16 - 19	24 - 26	> 30	> 30	> 30	> 16
Mpa	29 - 32	33 - 37	40 - 44	> 50	> 50	> 50	> 30
W/mk	> 110	> 130	> 130	> 55	> 55	> 55	> 110
10 <sup>-6</sup> /K bei 130°C		5,4 - 5,7		8,2			2,4
°C	180	200	200	200	200	200	200
bar				> 85	> 90	> 80	> 70
%	< 0,05	< 0,05	< 0,05	> 8,5	> 9	> 8	> 7

\*All data are related to phenolic resin impregnated material \*\*All pipes can be offered with fibre support (T)



**Benefits**

- high mechanical strength ·
- modular design ·
- good resistance against impact ·
- compact design, minimum space required ·
- high thermal exchange rate even at ·
- low mass flow rates ·
- reliable operation ·
- easy maintenance and cleaning ·

**References**

- waste water ·
- acid contraction ·
- titanium dioxide ·
- fine chemicals ·
- fertiliser ·
- pesticide ·
- pharmaceuticals ·
- Hydrochloric acid ·

**Applications**

- evaporator ·
- condenser ·
- cooler ·
- heater ·

**Service**

- thermodynamic design ·
- maintenance training ·
- standard blocks on stock ·
- customized design ·
- service teams ·

**Technical Data**

operating temperature

operating pressure

heat transfer areas

block diameter

pass way

product side

service side

shell options

The diameter of the drilling is designed according to the process data.

Heat exchanger are made according to the European Pressure Code, DIN and ANSI norm

# Block Heat Exchanger

## Cylindrical Blocks

The cylindrical block heat exchanger is based on round graphite blocks which may reach diameters of up to 1400 mm. It has pass way drillings for the product and the service medium. The size of the drilling varies with the properties of the media from 10 to 24 mm. An optimized drilling is needed to achieve best results for each process. The individual blocks are sealed with PTFE gaskets against each other and the whole package is fastened by springs. The sealing system works in the temperature range of the unit and has been established for many years. By innovative baffles the service media can be adopted to the process individually, which allows an optimized design.

Both sides of the heat exchanger may be corrosion resistant, by different shell materials like stainless steel, rubber lining other materials. Block heat exchangers are used for many applications because of their safe operation. The compact design offers low space requirement and the modular construction allows easy maintenance, cleaning and supports the adaption of the units for changed process conditions. The units have a low pressure drop and can be customized according to individual requirements for pressure, temperature, fouling and process media.

For Block heat exchanger there are 2 different designs available. The major difference of the type XYK and the type YKA is the way the service medium is let through the blocks. Please see the pictures below.

-20°C bis 170°C with phenolic impregnation

-20°C bis 240°C with PFA dispersion

6 bar, 10 bar on request

5 bis 500 m<sup>2</sup>/unit

300 bis 1.400 mm

10, 12, 14, 16, 18, 20, 22 mm

10, 12, 14, 16 mm

carbon steel, stainless steel, customised

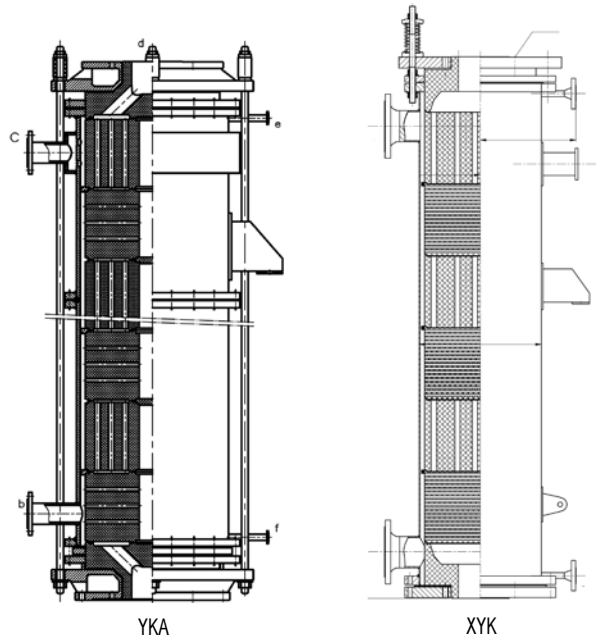

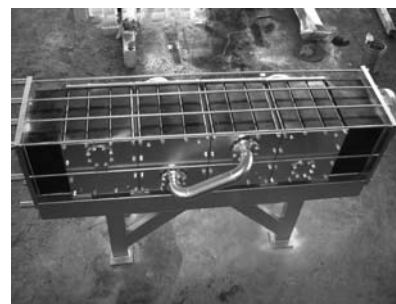

## Rectangular/Cubic Blocks

In addition to the cylindrical version, rectangular designs have been developed for various tasks like condensation and successfully introduced to the industry. Compared to the cylindrical design the service medium is not lead through a steel shell, but is transported by elbows and cast iron shields from one block to the next one. This system is very convenient for maintenance as each block can be cleaned individually. The blocks are fixed horizontally by tie rods and the system therefore has to take pressure in one direction only. PTFE gaskets are used for sealing.

Block heat exchangers are often used as condenser, because the condensate can be collected in the bottom part and can be removed easily.

### Design Options

- 1) horizontal installation
- 2) both sides corrosion resistant
- 3) optimized condensate removal

### Service

- thermodynamic design
- maintenance training
- standard blocks on stock
- customized design
- service teams

### Technical Data

operating temperature

operating pressure

heat transfer areas

block dimensions

pass way\*

product side

service side

shell options

The diameter of the pass way is designed according to the process data.

Heat exchanger are made according to the

European Pressure Code, DIN and ANSI norm

-20°C up to 150°C with phenolic impregnation

-20°C up to 240°C with PFA dispersion

3 bar, (10 bar on request)

5 bis 300 m<sup>2</sup>/unit

380 x 380 x 380 mm, 380 x 380 x 660 mm

380 x 760 x 660 mm, 380 x 1140 x 660 mm

drilling

10, 12, 14, 18, 20 mm

10, 12, 14 mm

carbon steel, stainless steel, customised

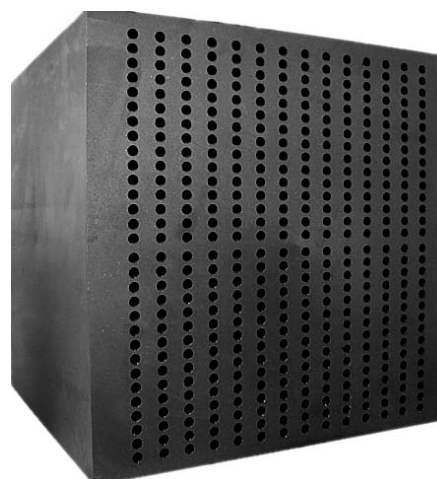
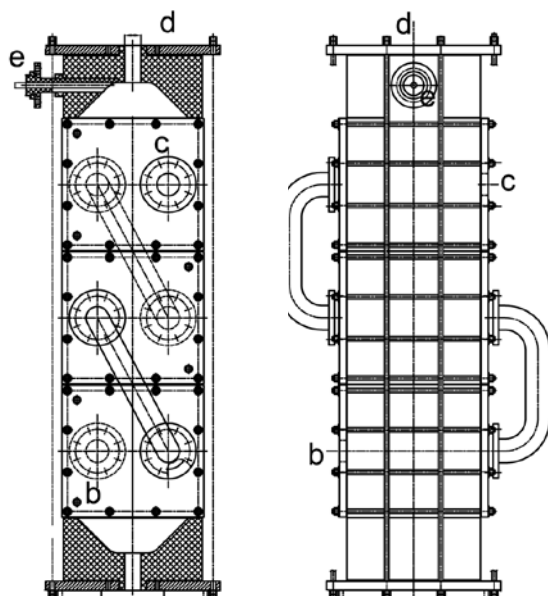



## Shell and Tube Heat Exchanger

Shell and tube or tubular heat exchangers are made of graphite tubes, which are connected to graphite tube sheets. On the shell side baffles support the tubes mechanically and guide the media flow.

### Applications

- evaporator ·
- condenser ·
- cooler ·
- heater ·
- falling film ·

### References

- Hydrochloric acid ·
- Sulphuric acid ·
- HF ·
- Phosphoric acid ·
- Chlorinated FCKW ·
- Waste acids ·

### Service

- thermodynamic design ·
- maintenance training ·
- customized design ·
- Service teams ·

### Technical Data

- operating temperature
- operating pressure

heat transfer areas

tube dimensions

tube length

shell options

The diameter of the drilling is designed according to the process data.

Heat exchanger are made according to the European Pressure Code, DIN and ANSI norm.

The heat exchangers offer a low pressure drop and are ideal for application where large mass flows require heat transfer areas of up to 1.000 m<sup>2</sup> per unit.

The diameter of the tubes is selected according to the media. Two standard sizes are available, which cover most applications. In order to achieve higher mechanical strength the tubes can be supported by carbon fibers. The units are successfully used as cooler and condenser.

The units are easy to maintain. If needed single pipes can be plugged.

Fiber supported pipes are available for higher pressure and temperatures.

-20°C up to 200°C

6 bar on shell side, 8 bar on request

6 bar on tube side

5 to 1.000 m<sup>2</sup>

32/22 mm or 50/36 mm

Carbon steel or customized

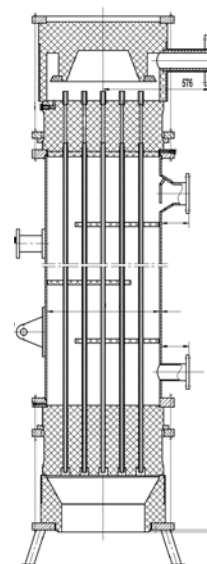

Single tube sealing

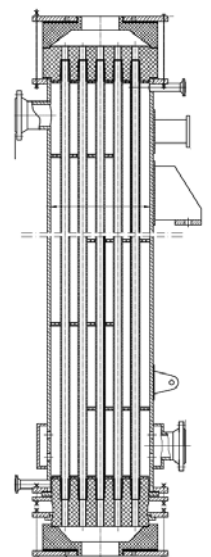

Floating Head



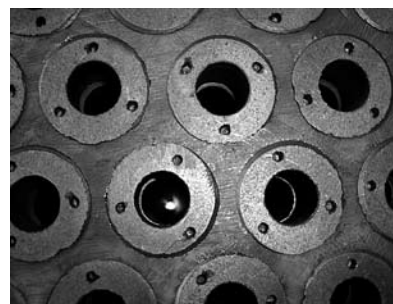

### Floating Head or single tube sealing

Due to the difference in thermal elongation of the graphite bundle and the steel shell the bundle can be subject to tensile or compressive strength. In order to compensate this stress the bundle can move independently from the shell by a floating head.

For severe conditions we have developed a single tube sealing, which reduces the stress on the tubes even more.

## Falling - Film Absorber

The turbulent graphite falling film absorber offers the benefit of a high absorption rate for a high concentrated medium together with a low outlet temperature and the result of a low concentrated HCL in the tail gas (usually 0,8 - 1,2 t/d per single tube). There is no contamination of the media to be found.

An example for the usage of this unit is the absorption of HCL for the production of hydrochloric acid. It is also successfully used for the falling - film absorption of gases like SO<sub>2</sub>, NH<sub>3</sub>, P<sub>2</sub>O<sub>5</sub> or H<sub>2</sub>S.

### Options

Model I: bottom sealer made of graphite

Model II: bottom sealer made of steel lined rubber

### Technical Data

< 170°C

operating temperature

1 bar tube side, max 6 bar

operating pressure

4 bar shell side, max 6 bar

5 up to 800 m<sup>2</sup>

heat transfer areas

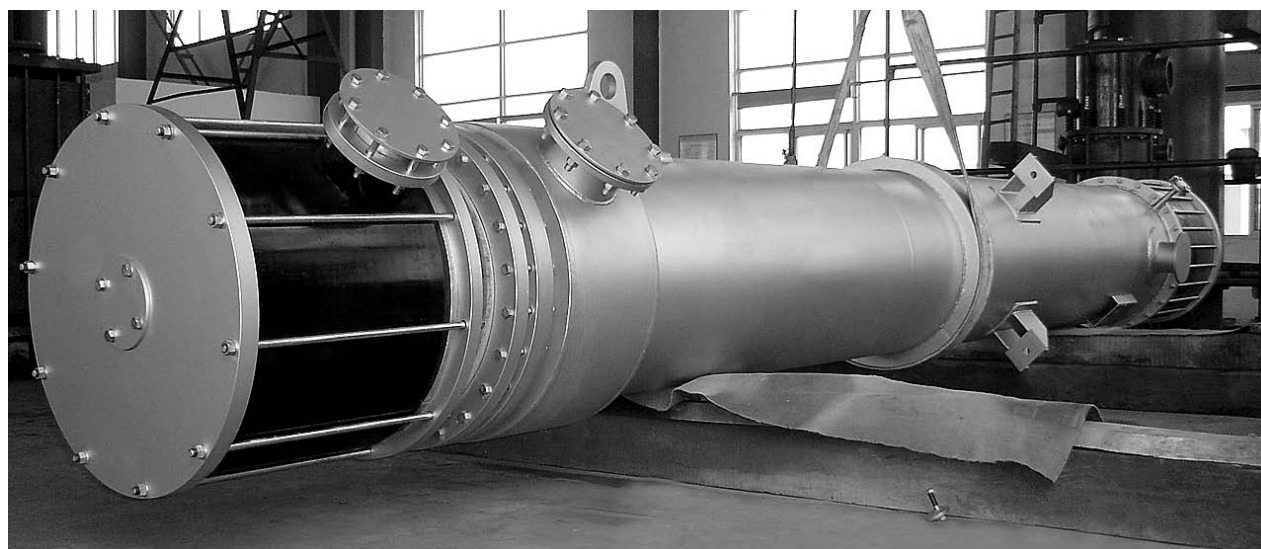



#### Support grids

Support grids are used in columns to support packing made of various materials suitable for the given process. The construction follows the maximum allowable flow rate, the required load and the size of the packing. It may either be flanged in between two column sections, or seated on a support ring.

#### Liquid distributor

Distributors for liquids are usually individually designed according to the data of the process. They serve to distribute the liquid of a process on the packing and at the same time allow the gases to pass. Accordingly they can have all kinds of different shapes and designs.

#### Inlet pipes

At certain points of a column the media involved in the process needs to be fed to the inner parts of the column, which can be sophisticated sprays or a simple inlet

#### Customized design

Many different kinds of column designs are available on request. Please send us your process data for an optimized layout.

#### Graphite columns

Columns made of graphite up to a diameter of 3000 mm are offered and designed according to customized processes. Please ask for details.

## Columns and Column Internals

Column internals like support grids, liquid distributors or inlet pipes are used to support the process in a column. Graphite has been chosen many times because of its many design options, which allow individual constructions for many different processes.

Columns and internals are available up to 3000 mm diameter.

Columns and column internals are designed individually according to the process data. This service is also available including the related guarantees. Many different forms and designs result from the many different tasks. Therefore we can only show some options here and ask for your individual data.

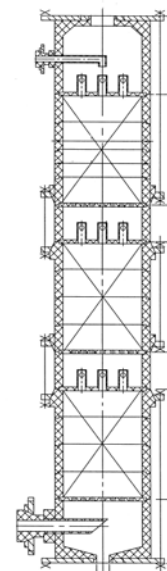
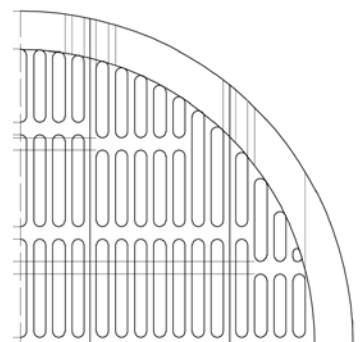
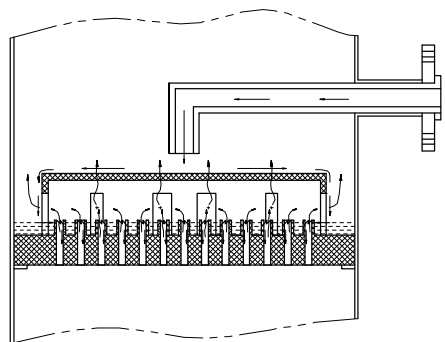

## Customized Heat Exchanger

### Cooler for high viscosity media

This modified rectangular block heat exchanger has been developed to cool high viscosity acids. The benefits achieved are:

- counter current cooling
- both sides corrosion resistant
- media pass ways of 16 to 24 mm with several drains due to high viscosity of the media
- short media holes for easy cleaning of crystallization
- self flow needs no feed pump
- F4 pickled graphite provides extremely good chemical resistance as an option



up to 240°C  
2 bar, product side, 3 bar water  
5 up to 300 m<sup>2</sup>

#### Technical Data

operating temperature  
operating pressure  
heat transfer areas

## Sulphuric Acid Dilution Cooler

For the dilution of sulphuric acid the unit is divided into two parts. In the upper part the acid gets mixed, diluted and distributed. This part consists of PTFE impregnated graphite and a two layer special mixing area for optimized mixing results. The lower part is a standard circular block heat exchanger unit used as a cooler.

This unit is used to reduce the concentration of sulphuric acid from 98% down to 65% or less and cools the acid down to 40°C in one step.

-20 °C to 180°C  
1 to 4 bar  
5 up to 500 m<sup>2</sup>

#### Technical Data

operating temperature  
operating pressure  
heat transfer areas

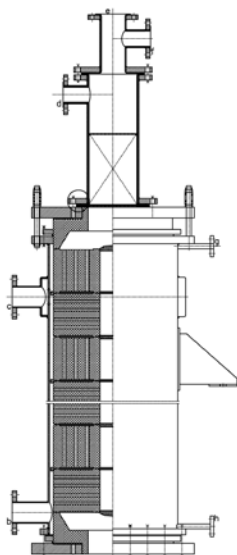

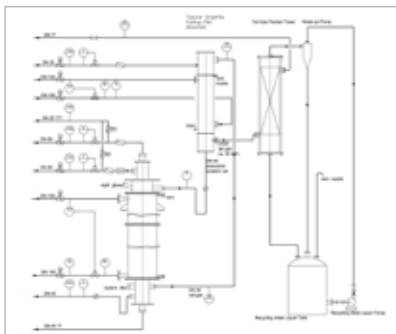

## Turn Key Process Technology

### Waste Sulphuric acid recovery process

In the process of for example the production of Titanium Dioxide one of the byproducts is low concentrated sulphuric acid, which needs to be recovered. The acid must be concentrated from 20% to at least 70% to be used in the process again, which is achieved by various evaporation steps and further treatment to the contaminated acid.

### High Purity HCL Gas

Based on 30% or lower concentrated HCL high purity HCL is achieved after purifying columns and following condensation steps. This process has been optimized in cooperation with European partners

### Hydrochloric acid recovery

In between the 3 most commonly used acids Hydrochloric acid is widely used in various applications. As a byproduct it can be recovered and purified in our process, which has continuously been improved and secured by 3 patents. Our major field of application is the hydrochloric acid from chloro acetic acid industry, chlorinated paraffin wax industry and chloride benzyl industry.

### Acetic acid concentration

Starting from 15 – 25% diluted acetic acid our process reaches 99% concentrated acid. The process has been developed with European partners and uses the benefits of our PTFE impregnated graphite.

### Waste gas treatment

Waste gases coming from the production processes have to be absorbed and recycled. In this absorption column gases are absorbed, recycled in one step, simplifying the process of repeated absorption and cooling. References are available for the treatment of gases like: HCL, CL<sub>2</sub>, SO<sub>2</sub>, H<sub>2</sub>S, HF, P<sub>2</sub>O<sub>5</sub>.

The units are standardized with capacities from 9 t/d up to 150 t/d for 35% - HCl. Customized units are available.

#### Technische Daten

Absorption rate:	99,9%
Absorption/day:	9 bis 150 t/d (35% HCl)
Max. Flow of Absorbant:	140 kg/h
Cooling water flow:	2 t/h

## HCL-Synthesis

### HCL-Synthese-units

During the process of hydrochloric acid synthesis the chlorine gas reacts with water by adding energy to HCL. This process is often used because of its reliable performance and the relatively small units.

The chemical reaction takes place in a furnace which is cooled by separated cooling water. Further steps may include absorption and the cooling of the HCL in one unit.

More than 100 turnkey units designed by Sunshine are installed with more than 15 years of life time.

### Water jacketed HCL Synthesis furnace

This very simple unit allows the synthesis in a very neat, mechanically strong unit, which usually serves for more than ten years. It consists of the inlets for the gas and the water supply as well as the burner. In order to take away the heat, cooling water is lead to the outside of the burning chamber.

### Three in one HCL furnace

This unit design allows three steps in one unit. The synthesis, absorption and cooling of the hot HCL down to 40 – 50 °C outlet temperature takes place in only one unit. With more than 100 units installed the technology presents not only the state of the art but includes some important patented features, which allow much higher efficiency than competitive units. The increase in efficiency is achieved by better wall protection in the reaction zone and more efficient heat transfer of the cooling water.

These units may be adopted to given processes or may be included in a complete system that can be offered as a turn key project Three in one furnace



#### Benefits:

- synthesis, absorption and cooling in one step
- high efficiency
- long lifetime
- turn key system available
- fits into given systems
- more than 100 units installed

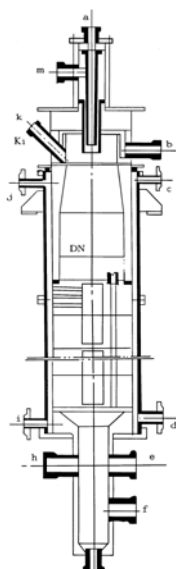

Three in one Furnace





## PTFE bellows

Bellows or expansion joints made of PTFE are connected to the graphite nozzles of heat exchanger. They compensate the vibrations and stress on the nozzle coming from the pipes work. Using PTFE as a material for our bellows means a very wide range of chemical resistance. The bellows come with CE marking and are also available with DIN ANSI or JIS connections. The PTFE is also available in antistatic.

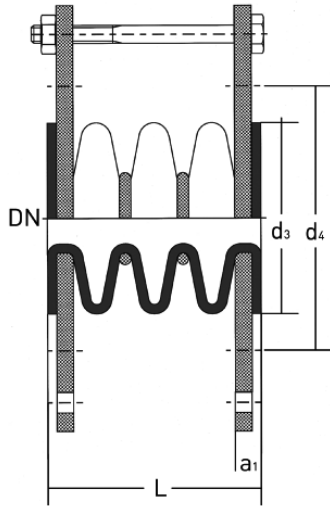

DN	L mm	Extension compr. ± mm	Misalign- ment max. mm	Angular Deflec- tion max. °	Vacuum resistance at				a <sub>1</sub>	Flared Surface d <sub>3</sub>	Bolt circle d <sub>4</sub>	no. of bolts x thread	Weight kg / piece
					10 <sup>5</sup> Pa	max. °C	10 <sup>5</sup> Pa	max. °C					
15	37	6	4	14	0,1	200			11,00	45	65	4 x M 12	1,7
20	37	6	4	14	0,1	200			11,00	58	75	4 x M 12	1,7
25	46	13	6	14	0,1	200			11,00	68	85	4 x M 12	1,7
32	46	13	6	14	0,1	200			13,00	78	100	4 x M 16	2,1
40	46	13	6	14	0,1	200			13,00	88	110	4 x M 16	2,6
50	56	15	9	14	0,1	200			15,00	102	125	4 x M 16	3,8
65	77	19	9	14	0,1	200			15,00	122	145	4 x M 16	4,6
80	77	25	13	14	0,1	200			15,50	138	160	8 x M 16	5,3
100	91	25	13	14	0,1	200			19,00	158	180	8 x M 16	7,0
125	111	25	14	14	0,1	150			19,25	188	210	8 x M 16	11,4
150	101	28	14	14	0,1	150			23,00	212	240	8 x M 20	12,7
200	137	28	14	14	0,1	50	2,0	150	25,00	268	295	8 x M 20	21,0
250	200	30	14	14	0,7	45	3,4	100	28,00	320	350	12 x M 20	27,0
300	196	30	15	14	1,5	45	6,7	100	31,00	378	400	12 x M 20	35,0
350	215	32	18	14	1,5	45	6,7	100	32,00	438	460	16 x M 20	60,0
400	233	35	20	14	1,5	45	6,7	100	34,50	490	515	16 x M 24	75,0
450	280	30	20	14	3,4	45	7,0	100	38,50	540	565	20 x M 24	91,0
500	327	30	25	14	---	---	8,0	100	40,50	610	620	20 x M 24	110,0



## Safety tapes

Safety tapes are used to protect the surrounding of flanges against uncontrolled spray outs and have to be used according to European regulation with aggressive, hazardous, hot or dangerous media.

Scanvex Safety tapes come in 50 m rolls and 5 different widths. From the table below the measurement of the tape can be taken and cut off from the roll with the suitable width. Then the tape is simply fixed by a screw.

DN	Bandlänge je Flansch	Bandbreite		
		Fest/Fest	Fest/Los	Los/Los
		mm	mm	mm
25	420	50	50	70
32	500	50	50	70
40	530	50	50	70
50	580	50	70	70
65	640	50	70	70
80	690	50	70	100
100	750	50	70	100
125	850	70	70	100
150	960	70	70	100
200	1130	70	100	100
250	1300	70	100	100
300	1460	70	100	140
350	1650	70	100	140
400	1840	100	100	140
500	2170	100	140	140
600	2510	140	140	180

### Safety shields

This safety device can not only be used with flanges but also with many other items included in a pipes system. It offers protection for bellows, armatures and also customized design.

The shields come with a PH indicator or a see through ECTFE in order to be able to detect any leakage visually. They are offered in various different materials to provide the best cost ratio.

### Material

The tape is made of transparent polypropylene with an UV stabilizer. Can be used from -40°C to 100°C

### Benefits

- Universally usage with 5 different width of the tape
- Transparent material allows visual control
- Minimized stock
- 50, 70, 100, 140 und 180 mm tape width
- Rolls of 50 meter

### Assembly

Please find the required length of the tape from the table and cut the length of the roll. Wrapped around the flange the overlapping ends are fixed by a VA screw.

### Customized design for

- Flange connections
- Bellows, expansions joints
- Pipe vents
- Ball valves
- T-type fittings
- Other specialty shields

### Materials:

- Teflon coated glass cloth
- Teflon and transparent ECTFE
- PCV, transparent option
- Polypropylene
- Polyethylene





## **WILK-GRAPHITE**

### **Büro Lörrach**

Am Sonnenrain 19 · 79539 Lörrach

Tel. 0049 (0) 7621 / 9140581

Fax. 0049 (0) 7621 / 9140582

[info@wilk-graphite.com](mailto:info@wilk-graphite.com)

[www.wilk-graphite.com](http://www.wilk-graphite.com)

### **Vertriebsbüro Köln**

Schanzenstr. 39 D3 · 51063 Köln

Tel: 0049 (0)221/ 9646602

Fax: 0049 (0)221/ 9646626

[a.hachenberg@wilk-graphite.com](mailto:a.hachenberg@wilk-graphite.com)

[www.wilk-graphite.com](http://www.wilk-graphite.com)

